

SERVO PRESSURE CALIBRATOR

SPC 3000

AND

CONTROL PRESSURE MODULE

CPM 3000

1722 North Madson Street

Liberty Lake, WA 99019

Tel: (800) 836-5161

(509) 891-9970

Fax: (509) 891-9481

web site: www.scanivalve.com

e-mail: scanco@scanivalve.com

Scanivalve Corp.



TABLE OF CONTENTS

INTRODUCTION	1-1
SYSTEM COMPONENTS	1-1
SPC3000	1-1
CPM3000	1-1
ZOCENCL2100	1-1
CALIBRATOR MODULE	1-2
SYSTEM SUPPORT	1-2
REQUIREMENTS	1-2
PRESSURE TRANSDUCERS	1-2
SERVO CONTROLLER	1-2
SOLENOID VALVES	1-2
CONTROL ELECTRONICS	1-3
CONTROL UNIT	1-3
SOFTWARE UTILITIES	1-3
USING THE MANUAL	1-4
GETTING STARTED	2-1
IDENTIFICATION OF CALIBRATOR FEATURES	2-1
INSTALLATION	3-1
SETTING THE CALIBRATOR ADDRESS	3-1
CABLE CONNECTIONS	3-1
CONNECTION OF THE COMMUNICATION LINK CABLE	3-1
CONNECTION OF THE CONTROL CABLE	3-1
PNEUMATIC CONNECTIONS	3-3
CONNECTION FROM CALIBRATOR TO PRESSURE SENSORS	3-3
AIR PRESSURE REQUIREMENTS	3-3
Control Air Supply	3-3
Servo Air Supply	3-3
SUPPLY AIR QUALITY	3-4
Particle Size	3-4
Dew Point	3-4
Oil Content	3-4
SUPPLY AIR CONSUMPTION	3-4
LINE PRESSURE CONFIGURATION	3-8
INITIAL TESTING	3-8
CALIBRATOR TUNING	3-9
CALIBRATOR OPERATION	4-1
INTRODUCTION	4-1
COMMAND TYPES	4-1
CONTROL COMMAND GROUP	4-1
CONFIGURE COMMAND GROUP	4-2
DIAGNOSTIC COMMAND GROUP	4-2

COMMAND FORMAT	4-3
CONTROL COMMAND GROUP	5-1
READ PRESSURE GROUP	5-2
READ PRESSURE	5-3
READ PRESSURE A	5-4
READ PRESSURE B	5-5
SET PRESSURE GROUP	5-6
GO POSITIVE	5-7
GO NEGATIVE	5-8
POSITIVE HIGH	5-9
POSITIVE MEDIUM	5-9
POSITIVE LOW	5-10
NEGATIVE HIGH	5-10
NEGATIVE MEDIUM	5-11
NEGATIVE LOW	5-11
INITIALIZE CALIBRATOR GROUP	5-12
INITIALIZE CALIBRATOR	5-13
ZERO PRESSURE	5-14
DISCRETE OUTPUT GROUP	5-15
ENERGIZE CLOSURE	5-16
SET CLOSURE	5-17
PURGE GROUP	5-18
PURGE	5-19
CONFIGURE COMMAND GROUP	6-1
CONFIGURATION VARIABLES	6-2
SET CONFIGURATION	6-17
NEW CONFIGURATION VARIABLES	6-18
NEW RANGES	6-19
SET MODE	6-20
SET POINTS POSITIVE	6-21
SET POINTS NEGATIVE	6-22
CALIBRATOR SERIAL NUMBER	6-23
SENSOR SERIAL NUMBER	6-24
MANUFACTURE DATE	6-25
READ CONFIGURATION	6-26
TRANSMIT CONFIGURATION VARIABLE	6-27
STATUS INQUIRY	6-28
DISPLAY CONFIGURATION VARIABLES	6-29
DISPLAY CONFIGURATION VARIABLES A	6-30
DISPLAY CONFIGURATION VARIABLES B	6-31
DISPLAY PRESSURE POINTS	6-32
BURN PROM	6-34
DIAGNOSTIC COMMAND GROUP	7-1
DISPLAY MEMORY NAME	7-2
SET MEMORY	7-3
DISPLAY PORT	7-4
SET PORT	7-5
DISPLAY A/D	7-6

ERASE FAULTS	7-7
DISPLAY FAULTS	7-8
READ VOLTAGE	7-10
DISPLAY PERIOD	7-11
DISPLAY PERIOD A	7-12
DISPLAY PERIOD B	7-13
CALIBRATION UNIT MAINTENANCE	8-1
TEST EQUIPMENT REQUIRED	8-1
CALIBRATION SYSTEMS WITH DIGIQUARTZ TRANSDUCERS	8-1
CALIBRATION SYSTEMS WITH MENSOR TRANSDUCERS	8-2
CALIBRATION SYSTEM DIAGNOSTICS	9-1
TRANSDUCER LEAK TEST	9-1
ABSOLUTE SECONDARY PRESSURE STANDARD	9-1
CALIBRATION SYSTEM LEAK TEST	9-3
REFERENCE SYSTEM LEAK TEST	9-4
REGULATOR MANIFOLD LEAK TEST	9-5
SOFTWARE UTILITIES	10-1
MCAL MENSOR COEFFICIENT PROGRAM	10-1
DQCAL DIGIQUARTZ COEFFICIENT PROGRAM	10-1
SPC 2000/2500/3000 SOFTWARE VERSIONS	11-1

FIGURES AND ILLUSTRATIONS

Figure 2-1 SPC3000 Calibrator System Front View	2-1
Figure 2-2 SPC3000 Calibrator Module Rear View	2-2
Figure 2-3 CPM3000 Rear View	2-3
Figure 2-4 CPM3000 Pneumatic Logic	2-4
Figure 2-5 Servo Calibrator Block Diagram	2-5
Figure 3-1 Typical Pneumatic Connections for Rack Mounted ZOC Modules	3-5
Figure 3-2 Typical Pneumatic Connections for Cable Service ZOC Modules	3-6
Figure 3-3 Recommended Air Supply System	3-7

COMMAND QUICK REFERENCE

[a]RP [/C] < CR >	5-3
[a]RPA [/C] < CR >	5-4
[a]RPB [/C] < CR >	5-5
[a]GP <i>value</i> <CR>	5-7
[a]GN <i>value</i> <CR>	5-8
[a]PH <CR>	5-9
[a]PM <CR>	5-9
[a]PL <CR>	5-10
[a]NH <CR>	5-10
[a]NM <CR>	5-11
[a]NL <CR>	5-11
[a]IC <CR>	5-13
[a]ZO <CR>	5-14
[a]EC <i>channel state</i> < CR >	5-16
[a]SC <i>pattern</i> < CR >	5-17
[a]PG <CR>	5-19
[a]NC <i>symbol data</i> [/H] < CR >	6-18
[a]NR <i>regulator standard</i> < CR >	6-19
[a]SM <i>pcode echo</i> < CR >	6-20
[a]SPP <i>phv pmv plv</i> < CR >	6-21
[a]SPN <i>nhv nmv nlv</i> < CR >	6-22
[a]CSN <i>cccccccccc</i> <CR>	6-23
[a]SSN <i>cccccccccc</i> <CR>	6-24
[a]MD <i>mmldd</i> (<i>yy</i> <CR>	6-25
[a]TC <i>symbol</i> [/HI <CR>	6-27
[a]SI < CR >	6-28
[a]DC [/HI<CR>	6-29
[a]DCA [/H] < CR >	6-30
[a]DCB [/H] < CR >	6-31
[a]DPP < CR >	6-32
[a]BP<CR>	6-34
[a]DMEM <i>seg offset</i> [/B,/W,/L] < CR >	7-2
[a]SMEM <i>seg offset data</i> [B,/W,/L] < CR >	7-3
[a]DPORT <i>port</i> [/B,/W] < CR >	7-4
[a]SPORT <i>port data</i> [/B,/W] < CR >	7-5
[a]DAD <i>mux</i> <CR>	7-6
[a]EFLT<CR>	7-7
[a]DFLT < CR >	7-8
[a]RV /C]<CR>	7-10
[a]DP [/C] <CR>	7-11
[a]DPA [/C] <CR>	7-12
[a]DPB [/C] <CR>	7-13

CONFIGURATION VARIABLES

PC	PRESSURE SENSOR CONFIGURATION	6-3
U0	U0 OR X0 COEFFICIENT FOR TEMPERATURE COMPENSATED DQ's	6-3
Y1	Y1 COEFFICIENT FOR TEMPERATURE COMPENSATED DQ's	6-3
Y2	Y2 COEFFICIENT FOR TEMPERATURE COMPENSATED DQ's	6-3
Y3	Y3 COEFFICIENT FOR TEMPERATURE COMPENSATED DQ's	6-3
C1	C1 COEFFICIENT FOR TEMPERATURE COMPENSATED DQ's	6-3
C2	C2 COEFFICIENT FOR TEMPERATURE COMPENSATED DQ's	6-3
C3	C3 COEFFICIENT FOR TEMPERATURE COMPENSATED DQ's	6-4
D1	D1 COEFFICIENT FOR TEMPERATURE COMPENSATED DQ's	6-4
D2	D2 COEFFICIENT FOR TEMPERATURE COMPENSATED DQ's	6-4
T1	T1 COEFFICIENT FOR TEMPERATURE COMPENSATED DQ's	6-4
T2	T2 COEFFICIENT FOR TEMPERATURE COMPENSATED DQ's	6-4
T3	T3 COEFFICIENT FOR TEMPERATURE COMPENSATED DQ's	6-4
T4	T4 COEFFICIENT FOR TEMPERATURE COMPENSATED DQ's	6-4
T5	T5 COEFFICIENT FOR TEMPERATURE COMPENSATED DQ's	6-5
C1	C COEFFICIENT FOR NON-TEMPERATURE COMPENSATED DQ's	6-5
D1	D COEFFICIENT FOR NON-TEMPERATURE COMPENSATED DQ's	6-5
T01	T0 COEFFICIENT FOR NON-TEMPERATURE COMPENSATED DQ's	6-5
U0B	U0 OR X0 COEFFICIENT FOR TEMPERATURE COMPENSATED DQ B	6-5
Y1B	Y1 COEFFICIENT FOR TEMPERATURE COMPENSATED DQ B	6-5
Y2B	Y2 COEFFICIENT FOR TEMPERATURE COMPENSATED DQ B	6-5
Y3B	Y3 COEFFICIENT FOR TEMPERATURE COMPENSATED DQ	6-6
C1B	C1 COEFFICIENT FOR TEMPERATURE COMPENSATED DQ B	6-6
C2B	C2 COEFFICIENT FOR TEMPERATURE COMPENSATED DQ B	6-6
C3B	C3 COEFFICIENT FOR TEMPERATURE COMPENSATED DQ B	6-6
D1B	D1 COEFFICIENT FOR TEMPERATURE COMPENSATED DQ B	6-6
D2B	D2 COEFFICIENT FOR TEMPERATURE COMPENSATED DQ B	6-6
T1B	T1 COEFFICIENT FOR TEMPERATURE COMPENSATED DQ B	6-6
T2B	T2 COEFFICIENT FOR TEMPERATURE COMPENSATED DQ B	6-7
T3B	T3 COEFFICIENT FOR TEMPERATURE COMPENSATED DQ B	6-7
T4B	T4 COEFFICIENT FOR TEMPERATURE COMPENSATED DQ B	6-7
T5B	T5 COEFFICIENT FOR TEMPERATURE COMPENSATED DQ B	6-7
C1B	C COEFFICIENT FOR NON-TEMPERATURE COMPENSATED DQ B	6-7
D1B	D COEFFICIENT FOR NON-TEMPERATURE COMPENSATED DQ B	6-7
T01B	T0 COEFFICIENT FOR NON-TEMPERATURE COMPENSATED DQ B	6-7
A	A COEFFICIENT FOR MENSOR TRANSDUCER	6-8
B	B COEFFICIENT FOR MENSOR TRANSDUCER	6-8
C	C COEFFICIENT FOR MENSOR TRANSDUCER	6-8
D	D COEFFICIENT FOR MENSOR TRANSDUCER	6-8
PCC	SELECT PRESSURE UNITS	6-9
PCO	SPECIAL PRESSURE UNITS	6-10
KI	SERVO INTEGRAL GAIN	6-10
KP	SERVO PROPORTIONAL GAIN	6-10
REG	REGULATOR OR SERVO BASED	6-10
SCPH	DISCRETE CONTROL FOR POSITIVE HIGH	6-11
SCPM	DISCRETE CONTROL FOR POSITIVE MEDIUM	6-12
SCPL	DISCRETE CONTROL FOR POSITIVE LOW	6-12

SCNM	DISCRETE CONTROL FOR NEGATIVE MEDIUM	6-13
SCNL	DISCRETE CONTROL FOR NEGATIVE LOW	6-13
SCGP	DISCRETE CONTROL FOR GO POSITIVE	6-13
SCGN	DISCRETE CONTROL FOR GO NEGATIVE	6-13
SCZO	DISCRETE CONTROL FOR ZERO	6-13
SCIC	DISCRETE CONTROL FOR INITIALIZE CALIBRATOR	6-13
SCPU	DISCRETE CONTROL FOR POWER UP	6-13
SCBH	DISCRETE CONTROL FOR HIGH BUTTON	6-13
SCBM	DISCRETE CONTROL FOR MEDIUM BUTTON	6-14
SCBL	DISCRETE CONTROL FOR LOW BUTTON	6-14
SCPI	DISCRETE CONTROL FOR PREPARE PURGE	6-14
SCP2	DISCRETE CONTROL FOR ACTUAL PURGE	6-14
SCP3	DISCRETE CONTROL FOR EXIT PURGE	6-14
DQPH	PRESSURE DQ HIGH LIMIT	6-14
DQPL	PRESSURE DQ LOW LIMIT	6-14
DQPH	TEMPERATURE DQ HIGH LIMIT	6-14
DQTL	TEMPERATURE DQ LOW LIMIT	6-15
PGD1	PREPARE AND EXIT PURGE TIME	6-15
PGD2	ACTUAL PURGE TIME	6-15
ADDR	CALIBRATOR ADDRESS	6-15
MEPH	ANALOG SENSOR HIGH LIMIT	6-15
MEPL	ANALOG SENSOR LOW LIMIT	6-15
SVH	SERVO MAXIMUM POSITION	6-15
SVL	SERVO MINIMUM POSITION	6-15
CHAN	ANALOG SENSOR INPUT CHANNEL	6-16
MESA	ANALOG SENSOR AVERAGE	6-16
MEG	ANALOG SENSOR CONVERSION FACTOR	6-16
MEGS	ANALOG SENSOR CONVERSION FACTOR SHIFT	6-16

CHAPTER 1 INTRODUCTION

The Scanivalve CALSYS3000 pressure calibration system is designed to generate and precisely measure pressures for the calibration of pneumatic pressure sensors. The calibration system can be used in a stand-alone configuration or as a major component of an integrated system such as the Scanivalve Corporation HyScan 2000 or 1000 pressure measurement system.

SYSTEM COMPONENTS

The **CALSYS3000** is modular and flexible thus supporting a wide range of customer requirements. Basic system components consist of:

SPC3000

Calibrator module which supplies and measures the precision calibration pressure.

CPM3000

Solenoid Control Unit which supplies power to the calibrators and switches system pressures.

ZOCENCL2100

An enclosure used to house the Calibrator and the Solenoid Control Unit in a standard 19" rack enclosure.

A basic CALSYS3000 system provides calibration for one pressure range. This system would consist of one CPM3000 Solenoid Control Unit module, one SPC3000 Calibrator module, and one ZOCENCL2100 19" rack enclosure.

A larger CALSYS3000 system is capable of providing calibration for multiple pressure ranges. A system could contain up to 14 SPC3000 Calibrator modules.

One CPM3000 unit is required for any number of SPC3000 calibrator modules. One 19" test rack enclosure can hold up four calibrator modules.

This manual will refer to the CALSYS3000 as the calibration system, the CPM3000 as the control unit and the SPC3000 as the calibrator.

CALIBRATOR MODULE

SYSTEM SUPPORT

The calibration system requires a regulated instrument air source, an RS-232 communication link and AC power.

REQUIREMENTS

Supply air is used as a source for the generation of the precision pressure. Control air is used for switching solenoids.

The calibrator is controlled by issuing commands over an RS-232 communication link. Information is also returned from the calibrator over the same link. When the calibration system is part of a HyScan system the communication is controlled by the HyScan software.

AC Power required is 120 or 220 VAC, 50-60 Hz. The power requirements must be specified at the time of order.

The calibration module generates and measures multiple calibration pressures and ambient/zero pressure. The major components of the calibrator include a pressure transducer, a servo controller, pneumatic solenoid valves and an 80186 microprocessor for control.

PRESSURE TRANSDUCERS

The calibrator module uses one of two user specified secondary pressure standards to read calibration pressures. The secondary pressure standard can either be an absolute or a differential pressure transducer. Typical accuracies are $\pm 0.01\%$ of full scale.

Available pressure standards are:

- 1) Mensor Model 11603 (data sheet at rear of manual). This is a force balance Quartz Pressure Transducer with an analog output.
- 2) Paroscientific DIGIQUARTZ Series 2000, referred to as DQ, (data sheet at rear of manual). This is a quartz resonator where the frequency output is a function of the pressure input. The standard sensor is an absolute sensor. A differential version is available at an increased cost and extended delivery time.

SERVO CONTROLLER

The calibrator uses a servo valve with a PID control loop to control the precision output pressure.

SOLENOID VALVES

The control unit contains pilot operated pneumatic solenoid valves. The valves are designed to set the calibrator to pre-determined configurations during calibrations and perform diagnostic leak tests for an entire calibration system, including the calibration module.

CONTROL ELECTRONICS

At the heart of the calibrator control electronics is a 12 MHz 80186 microprocessor. Three different types of memory are used on board: 16 kBytes of RAM for temporary storage of data, 64 KBytes of ROM for storage of the program and constants and 16 KBytes of EEPROM. Counters, A/D converters and D/A converters are also used.

CONTROL UNIT

The Control Unit module contains the solenoid valves for providing control pressures to the ZOC electronic pressure scanners. The Control Unit can fit into one of the enclosure slots or can be directly mounted in the test rack through the use of a conversion kit. One Control Unit module can support any number of Calibrator modules.

SOFTWARE UTILITIES

Software utility programs will be provided upon request. The programs may be used to recalibrate the secondary pressure standard. The software is designed to operate on a DOS based computer.

The MCAL program is provided to re-compute calibration coefficients when a Mensor secondary standard pressure transducer is recalibrated.

The DQCAL program is provided re-compute calibration coefficients when a Digiquartz secondary standard pressure transducer is recalibrated. This program is property of PAROSCIENTIFIC and may not be distributed or modified without their consent.

USING THE MANUAL

The Calibrator System Manual contains eleven chapters.

Chapter 1, Introduction

Provides a basic overview of the calibration system.

Chapter 2, Getting Started

Describes the system components and features.

Chapter 3, Installation

Describes the interface of the calibration system to a HyScan Data Acquisition system.

Chapter 4, Calibrator Operation

Details the operation of the calibrator and provides an overview of calibrator commands.

Chapter 5, Control Commands

Details the commands for controlling the operation of the calibrator.

Chapter 6, Configuration Commands

Details the commands and methods for setting up the calibrator.

Chapter 7, Diagnostic Commands

Details the commands used for diagnosing calibrator problems.

Chapter 8, Maintenance

Details routine maintenance tasks.

Chapter 9, Diagnostics

Details troubleshooting aids.

Chapter 10, Software Utilities

Describes the operation of the software utilities provided.

Chapter 11, Software Versions

Describes the various software versions.

Transducer data sheets and calibrator schematics are provided at the rear of the manual.

CHAPTER 2 GETTING STARTED

The pressure calibration system has been carefully packed to minimize the possibilities of damage in transit. It is very important that the user carefully inspect all system components. Any damage should be reported immediately to Scanivalve Corporation.

It is important that the user read and fully understand the operation of the CALSYS3000 Calibration System before attempting to operate the system.

The user should become familiar with the main features and connections of the calibrator and control unit. To assist in this process, this manual provides the following section entitled Identification of Calibrator Features.

IDENTIFICATION OF CALIBRATOR FEATURES

This section identifies the calibrator system's component features. Figure 2-1 shows the front view of the calibrator system. Figure 2-2 shows the rear view of the calibrator module. Figure 2-3 shows the rear view of the control unit. Figure 2-4 shows the logic of the control unit. A block diagram of the Calibrator module is shown in Figure 2-5

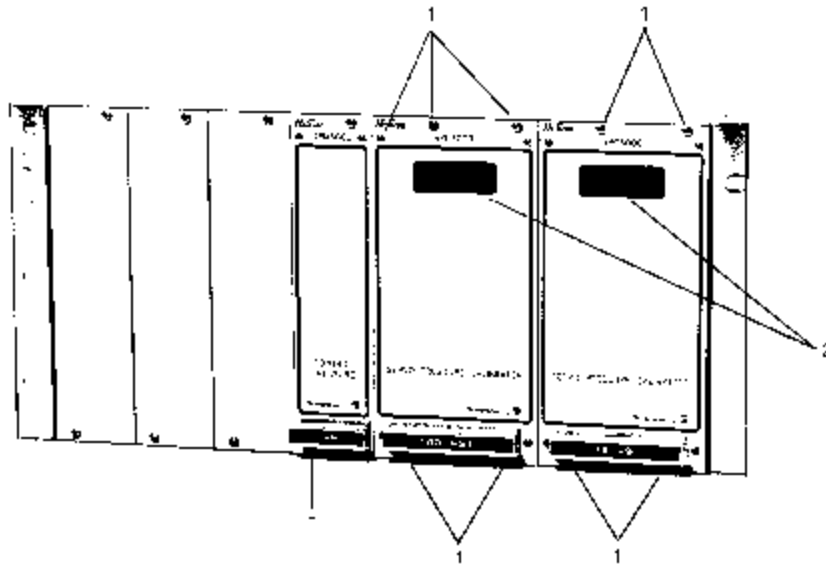

Figure 2-1 SPC3000 Calibrator System Front View

- 1) Screws for installing the SPC3000 module and the CPM3000 module.
- 2) Display - Shows commands received from host, returned pressure, or any calibrator faults.

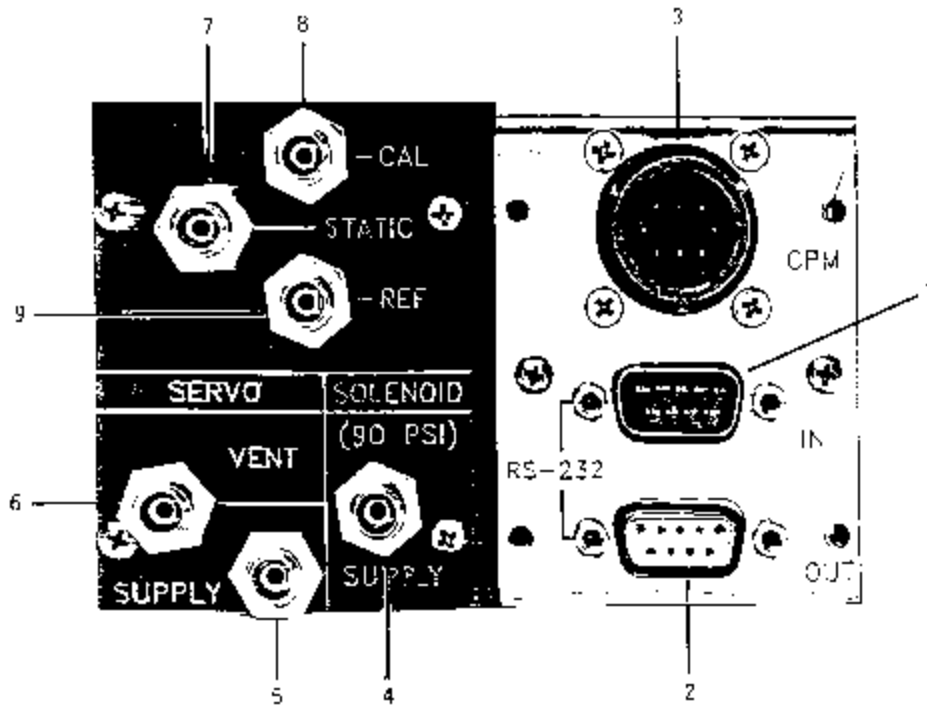

Figure 2-2 SPC3000 Calibrator Module Rear View

- 1) J2 - a DB9 female connector for RS-232 input from the DAQ2000, CRT, or host computer.
- 2) J1 - DB9 male connector for RS-232 output to other calibrator modules.
- 3) Solenoid Control - External solenoid valve control connector for use with control unit and other special applications.
- 4) Solenoid Supply - Solenoid supply air input. 90 - 100 psi required.
- 5) Servo Supply - Servo supply air input. The requirements vary with the full scale range of the calibrator module. Refer to Pressure Requirements on Page 3-5 for additional information.
- 6) Servo Vent - Vent output for excess input air or vacuum supply input.
- 7) Static - Pressure reference for the differential ZOC electronic pressure scanners and differential secondary pressure standard.
- 8) Cal(+) - Calibration pressure output to ZOC electronic pressure scanners.
- 9) Ref(-) - Reference pressure output to ZOC electronic pressure scanners.

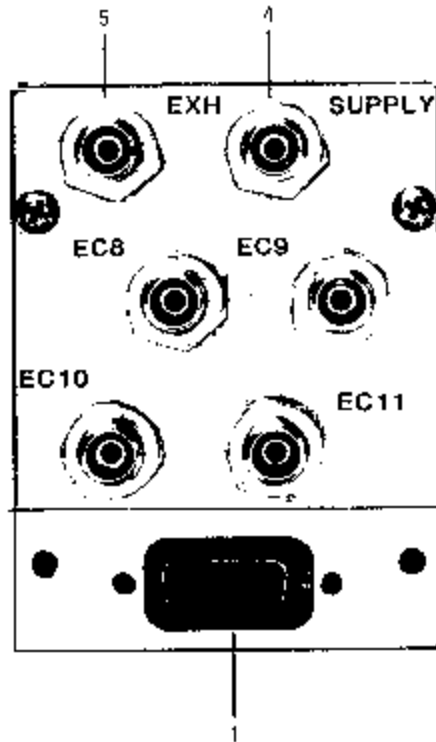

Figure 2-3 CPM3000 Rear View

- 1) J1 - Control Input connection from a Servo Calibrator
- 2) EC8, EC9 - Control pressure outputs for ZOC electronic pressure scanners. Refer to figure 2-4 for more information.
- 3) EC10, EC11 - Control pressure outputs for ZOC electronic pressure scanners. Refer to figure 2-4 for more information.
- 4) Supply - Input Supply pressure, 65 to 90 psi depending upon the module type. Refer to the applicable module manual for the actual pressure requirements.
- 5) Exhaust - Solenoid vent line, normally open to ambient pressure. A vacuum source may be required with ZOC12 pressure scanning modules.

SUPPLY = 90 PSI CLEAN DRY AIR

COMMAND	MODE				ZOC CONTROL
	Px	CAL	ISOLATE	PURGE	
EC 8	OFF	ON	ON	OFF	CAL CTL
EC 9	ON	OFF	ON	OFF	Px CTL

CPM 3000 USED WITH NORMAL OPEN TYPE ZOC'S

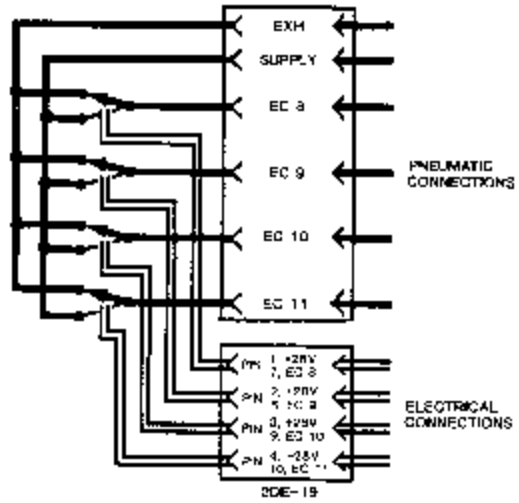

SUPPLY = 90 PSI CLEAN DRY AIR

COMMAND	MODE				ZOC CONTROL
	PxA	PxB	CAL	ISOLATE	
EC 8	OFF	ON	ON	OFF	CTL 1 NP
EC 9	OFF	ON	OFF	ON	CTL 2
EC 10	OFF	ON	ON	ON	CTL 1 IP
EC 11	OFF	OFF	OFF	ON	PRG CTL

CPM 3000 USED WITH NORMAL, PxA/ISOLATE PURGE TYPE ZOC'S

SUPPLY = 90 PSI CLEAN DRY AIR

COMMAND	MODE				ZOC CONTROL
	PxA	PxB	CAL	ISOLATE	
EC 8	ON	ON	OFF	ON	CAL CTL
EC 9	OFF	ON	ON	ON	PxA CTL
EC 10	ON	OFF	ON	ON	PxB CTL

CPM 3000 USED WITH ZOC22/28 PxA X 2 MODULES

Figure 2-4 CPM3000 Pneumatic Logic

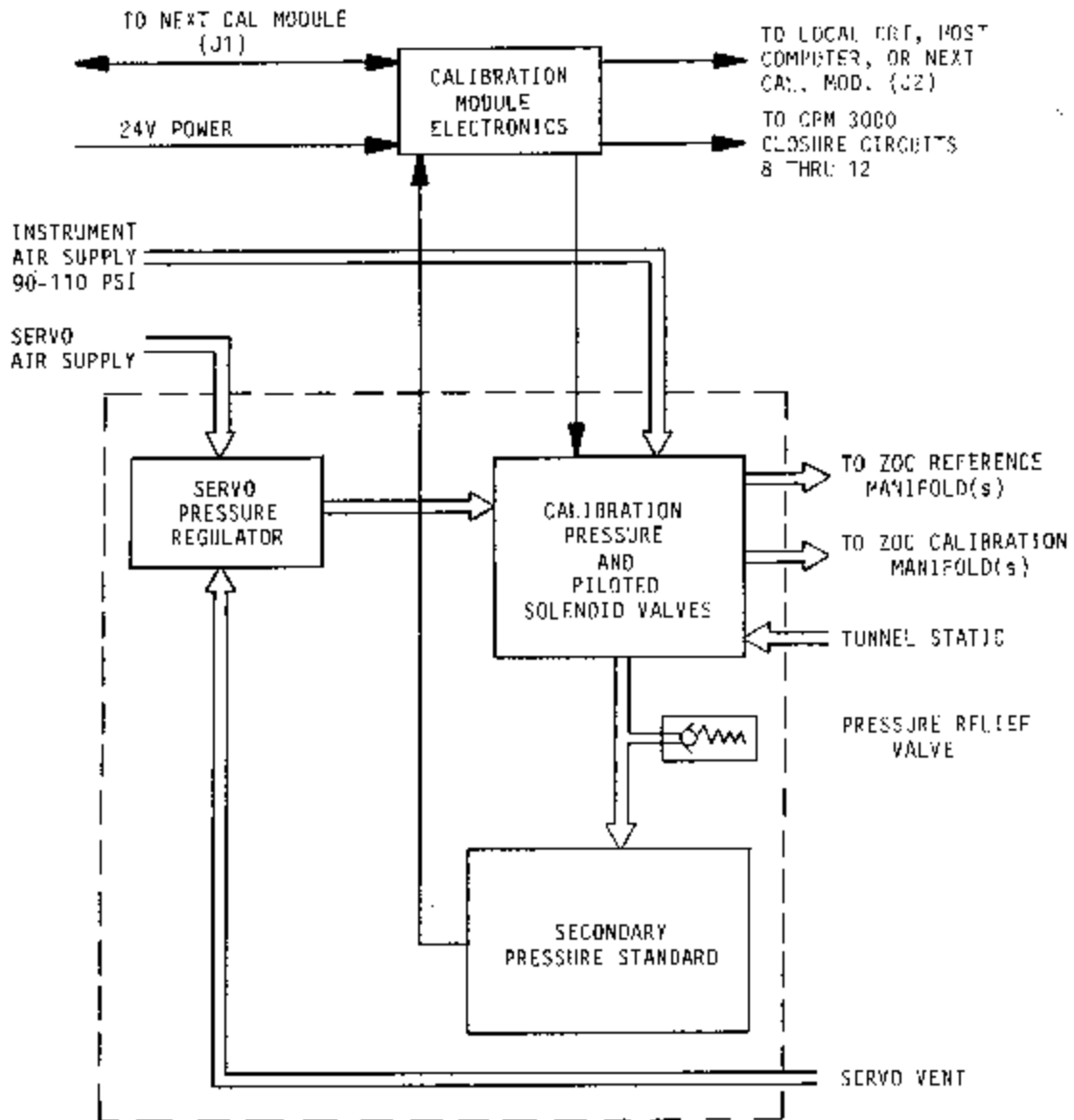

Figure 2-5 Servo Calibrator Block Diagram

CHAPTER 3 INSTALLATION

This chapter provides general installation information for the calibrator system. For installation in HyScan 2000 or 1000 systems please refer to those manuals.

SETTING THE CALIBRATOR ADDRESS

Each calibrator module has a unique identifier, called an address. The valid addresses are 1, 2, 3, 4, 5, 6, 7, 8, 9, U, V, W, and Y. In a system with multiple calibrator modules, the RS-232 communication cables are "daisy chained" through each calibrator. The address is necessary to identify the individual calibrator on the RS-232 link. When only one calibrator is used, it should be set to address 1. The address character precedes each command issued over the RS-232 link. Command syntax is covered in the Calibrator Operation chapter.

This address is set by placing the proper jumpers on the large processor circuit board. Drawing 18096, at the end of this manual, shows the jumper position for selecting a calibrator address. If all four jumpers are installed, the determination of the address is handled by the configuration variable "ADDR". This is covered in detail in the Calibrator Operation Section, Chapter 4.

When the address of the calibrator is unknown, it may be found by first ensuring that the calibrator is the only one on the RS-232 link. Next issue a sequence of SI commands prefixed with each possible address. The calibrator will only respond when correctly addressed.

CABLE CONNECTIONS

This section describes the connection of external power, control, and communication cables to the calibration system and between calibrator system modules.

CONNECTION OF THE COMMUNICATION LINK CABLE

The controlling device, which can be a CRT terminal, a host computer, a DAQ2000, or a DAQ1000 is connected via an RS-232 cable to the calibration module at the J2 connector.

The communication interface characteristics are full duplex, 9600 BAUD, 10 bit character with 1 start bit, 8 data bits in ASCII code, 1 stop bit and no parity.

A single controlling device with one RS-232 link may drive up to fourteen (14) calibration modules in a daisy chain arrangement. A cable is run from J1 of calibrator module one to J2 of calibrator module two, from J1 of calibrator module two to J2 of calibrator module three, et cetera.

CONNECTION OF THE CONTROL CABLE

The control cable is connected from the Solenoid Control connector on the Control Unit module to the Solenoid Control connector on the Calibrator module addressed as calibrator 1.

Each calibration module contains 12 discrete outputs or closure circuits labeled 1 through 12. These outputs are controlled by means of the closure control commands, EC and SC, described in the Calibrator Operation chapter.

Each circuit provides a maximum of 100 milliamperes current at 24 Vdc. The first seven closure circuits, numbered 1 through 7, are used to control internal valves. The internal connection is shown in drawings 17980 at the rear of this manual. The remaining five, numbered 8 through 12, are available at the connector labeled "Solenoid Control" on the rear panel. These external discrete outputs are for customer use. Refer to drawing 80613 at the end of this manual for pin assignments.

An example of using external discrete outputs is to operate an external solenoid valve used to shut off the air supply when the system is not in use.

PNEUMATIC CONNECTIONS

This section describes the pneumatic requirements of the calibration system.

CONNECTION FROM CALIBRATOR TO PRESSURE SENSORS

The calibration module is designed to facilitate calibration of both sides of the ZOC pressure sensors without the necessity of vacuum sources. To use this feature, the positive side of the sensor is connected to the CAL(+) fitting on the rear panel of the module, and the negative side is connected to the REF(-) fitting. During a positive calibration, pressure is applied to the sensors through the CAL(+) fitting. During a negative calibration, pressure is applied through the REF(-) fitting. This simulates a vacuum on the positive side of the ZOC differential pressure sensor.

Figure 3-1 shows typical pneumatic connections for a Calibration System in a ZOC rack mount enclosure. Figure 3-2 shows typical pneumatic connections for a Calibration System with ZOC cable service modules.

AIR PRESSURE REQUIREMENTS

Control Air Supply

The calibration module solenoid valves require 90 to 125 psi for positive actuation. It is essential that the control air supply sources be regulated with a good quality relieving regulator at a pressure within the recommended ranges.

Servo Air Supply

The control air supply should **NOT** be used for the servo supply air connection. Figure 3-3 shows a recommended instrument air supply system. The servo air supply must be well regulated within a small input range for each calibrator range in order to obtain optimum performance. The recommendations in the following table must be observed:

Calibrator Range (PSI)	Servo Supply (PSI)
1	1.5 to 2.5
2.5	3 to 5
5	7.5 to 10
15	18 to 25
30	35 to 45
50	55 to 65
100	105 to 125
200	205 to 225
300	305 to 325
500	505 to 525
750	755 to 775

SUPPLY AIR QUALITY

Air supplies to the calibration module must be of quality typical for sensitive instrumentation. Requirements can be found in the Instrument Society of America's "Quality Standard for Instrument Air" (ISA-S7.3). This standard calls for the following:

Particle Size

The maximum particle size at the instruments should not be larger than 3 microns.

Dew Point

The dew point, at line pressure, should be at least 10EC or 50E F below the minimum temperature to which any part of the instrument system is exposed at any season of the year. Dew point should never exceed 2EC or 35E F at line pressure.

Oil Content

The maximum total oil or hydrocarbon content, exclusive of non-condensing particulate should not exceed 1 PPM under normal operating conditions.

SUPPLY AIR CONSUMPTION

Actual air consumption will depend on supply air pressure, settings of the regulators, the amount of air demanded from the rear panel fittings and will vary from module to module. The following table gives an indication of what may be anticipated.

Calibrator Range (PSI)	Instrument Air Consumption (SCFM)
1	0.5
5	0.5
15	0.5
50	0.5
100	0.8
200	0.9
500	1.4
750	2.0

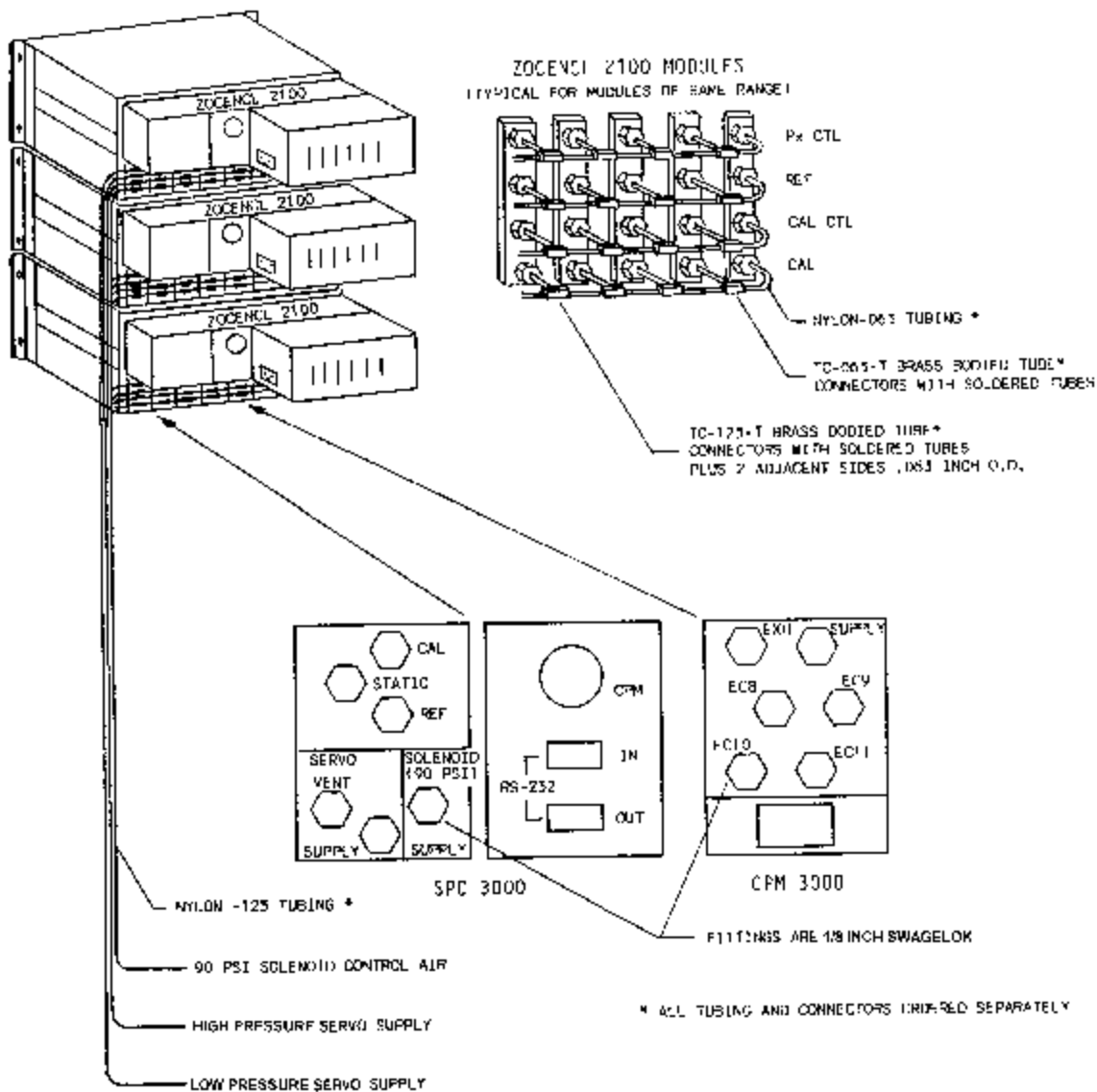

Figure 3-1 Typical Pneumatic Connections for Rack Mounted ZOC Modules

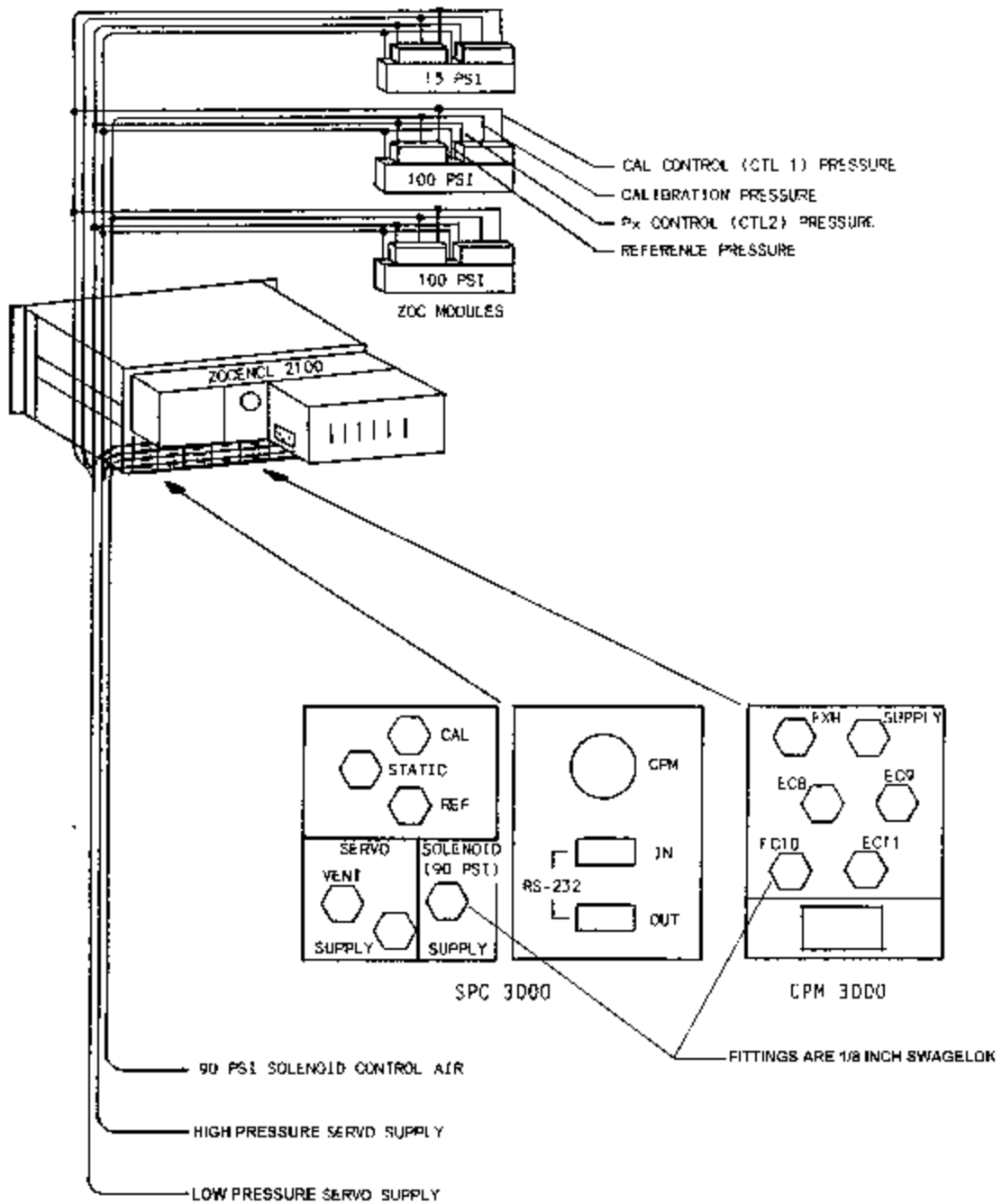
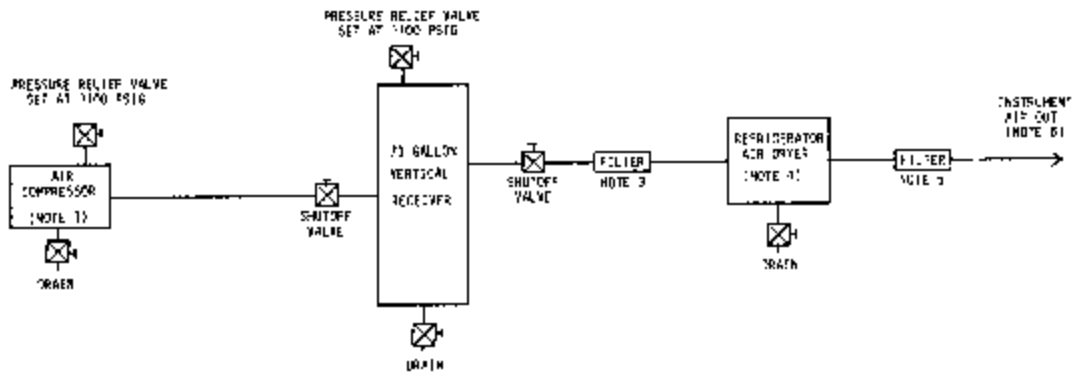

Figure 3-2 Typical Pneumatic Connections for Cable Service ZOC Modules



NOTES:

1. Ingersol Rand Model 41 or equivalent
 Pressure Output 1000 psig
 Output Flow 6.1 ACFM
2. Pressure Tubing is Parker Parflex 560 or equivalent
 2500 psi working pressure
3. Balston Type 85 or equivalent
 Element 0.1 micron
 Efficiency 93%
4. Zeks refrigerated air dryer or equivalent
 Must lower dewpoint to 35EF
5. Balston Type 85 or equivalent
 Element 0.1 micron
 Efficiency 99.99%
6. Final Instrument Air Output conforms to ISA-S7.3

Figure 3-3 Recommended Air Supply System

LINE PRESSURE CONFIGURATION

Regulator reference is a non-standard feature. Consult the factory if this feature is required.

The calibrator module may be operated at a line pressure other than ambient by manifolding the regulator reference and tunnel static connections on the rear panel. It is important to note that the secondary pressure standard may be either an absolute or a differential pressure transducer. When Calibrator commands are executed, the pressure differential applied to the sensor(s) is the difference between the pressure output of the calibration manifold and the pressure in the tunnel static line. Ambient pressures are achieved by connecting the positive and negative sides of the sensors to the tunnel static line. Care must be taken to avoid over-ranging the secondary pressure standard or the sensor(s) being calibrated. The user should understand drawing 17980 sheets 8 and 10 located at rear of manual.

INITIAL TESTING

The procedure for conducting the initial test depends on how the calibrator system is used. In the stand-alone mode, a CRT terminal or host computer is used to communicate with the calibrator system. When the calibrator system is part of a HyScan 1000 or 2000, the DAQ is used to communicate with the calibrator system. Please refer to the appropriate HyScan manual for more information.

PROCEDURE

- 1) Connect all electrical cables.
- 2) Connect the proper air sources.
- 3) Energize the Calibrator System.
The calibrator(s) will transmit a sign on message to the terminal.
- 4) Type: [a]SI <enter > where: [a] is the calibrator address
The module should respond with an identification message. Insure that the correct address precedes each command. Refer to the command syntax in the Calibrator Operation section.
- 5) Ensure that the static fitting on the rear panel is open to ambient.
- 6) Type: [a]RP <enter > where: [a] is the calibrator address
If the calibrator contains an absolute pressure standard, the calibrator will return a value equal to ambient pressure. If the calibrator contains a differential pressure standard, the value returned will equal the zero offset of the transducer.
- 7) If the value obtained in the previous step is a valid number, procede to the next section. If a value cannot be obtained or if the value is no believable, contact Scanivalve Corp, Product Support Department.

CALIBRATOR TUNING

The SPC3000 utilizes a PID control loop for all pressure output operations. Although the Calibrator has been tested for proper control loop operation, this control loop must be tuned to account for differences in Output Volume, Servo Supply Pressure, and Servo Supply Flow Capacity from the Scanivalve Corp Test Department and the End Users Facility.

The calibrator tuning may be accomplished without having to modify a user's setup. The user should be operating in a Direct Communication Mode. This could be via a Communication program such as PROCOMM, Windows Terminal, Windows HyperTerminal or any other program that can communicate with the SPC3000 and display returned information.

PROCEDURE

If the Initial Testing has just been completed, skip to step 5

- 1) Connect all electrical cables.
- 2) Connect the proper air sources.
- 3) Energize the Calibrator System.
The calibrator(s) will transmit a sign on message to the terminal.
- 4) Type: [a]SI <enter > where: [a] is the calibrator address
The calibrator should respond with an identification message. Insure that the correct address precedes each command. Refer to the command syntax in the Calibrator Operation section.
- 5) Type: [a]TUNE<enter> where: [a] is the calibrator address.
The calibrator will commence a self tuning routine. A series of numbers and responses will scroll on the computer screen. The process should be completed within a few minutes. If the unit appears to be in a loop press <Esc> to terminate the tuning process.
- 6) At the end of the tune process a series of calculated numbers will be displayed. At the same time the calibrator will be reset.
- 7) Type: [a]BP<enter> where [a] is the calibrator address.
This will save the new control loop gains.
- 8) Test the gain settings by commanding the calibrator to some pressure outputs. Use the GP or GN commands. Refer to the Calibrator Operation Section, Chapter 4, for more information.
- 9) If the control loop gains are correct, the calibrator output should reach a commanded pressure quickly with minimum overshoot and recover in one cycle. Pressure output should remain stable.
- 10) If the control loop is not stable, or cannot be tuned, test for:
 - Leaks on the output
 - Improper servo supply pressure(toohigh or too low)
 - Restricted servo supply airflow

CHAPTER 4 CALIBRATOR OPERATION

INTRODUCTION

The calibrator accepts commands and transmits data via a RS-232 communication link. All commands and data are 8 bit standard ASCII code with no parity. Commands are not case sensitive.

COMMAND TYPES

The calibrator has three major command groups: Control, Configuration, and Diagnostics. The following table summarizes the commands and provides a quick page reference for more information.

CONTROL COMMAND GROUP

COMMAND FUNCTION	COMMAND	PAGE
Read Pressure	RP	5-3
Read Pressure A	RPA	5-4
Read Pressure B	RPB	5-5
Go Positive	GP	5-7
Go Negative	GN	5-8
Positive High	PH	5-9
Positive Medium	PM	5-9
Positive Low	PL	5-10
Negative High	NH	5-10
Negative Medium	NM	5-11
Negative Low	NL	5-11
Initialize Calibrator	IC	5-13
Zero Pressure	ZO	5-14
Energize Closure	EC	5-16
Set Closure	SC	5-17
Purge	PG	5-19

CONFIGURE COMMAND GROUP

COMMAND FUNCTION	COMMAND	PAGE
New Configuration Variable	NC	6-18
New Ranges	NR	6-19
Set Mode	SM	6-20
Set Points Positive	SPP	6-21
Set Points Negative	SPN	6-22
Calibrator Serial Number	CSN	6-23
Sensor Serial Number	SSN	6-24
Manufacture Date	MD	6-25
Transmit Configuration Variable	TC	6-27
Status Inquiry	SI	6-28
Display Configuration Variable	DC	6-29
Display Configuration Variables A	DCA	6-30
Display Configuration Variables B	DCB	6-31
Display Pressure Points	DPP	6-32
Burn Prom	BP	6-34

DIAGNOSTIC COMMAND GROUP

COMMAND FUNCTION	COMMAND	PAGE
Display Memory	DMEM	7-2
Set Memory	SMEM	7-3
Display Port	DPORT	7-4
Set Port	SPORT	7-5
Display A/D	DAD	7-6
Erase Faults	EFLT	7-7
Display Faults	DFLT	7-8
Read Voltage	RV	7-10
Display Period	DP	7-11
Display Period A	DPA	7-12
Display Period B	DPB	7-13

COMMAND FORMAT

Each of the commands are explained with the following sections: command name, command syntax, command returns, command description, and command examples.

The **COMMAND NAME** section list the name of the command.

The **SYNTAX** section lists the format of the command. The following conventions are used:

EXAMPLE	DESCRIPTION
BP	Boldface letters indicate command keywords and operators. Within the discussion of syntax, bold type indicates that the text must be entered exactly as shown.
<i>expression</i>	Words in italics indicate placeholders for information you must supply, or information returned by the calibrator, such as a coefficient name or pressure data. Italics are also occasionally used for emphasis in the text.
[/H]	Items in square brackets are optional.
,	Commas separates options, only one of the options may be used.
<CR>	Items in angle brackets are used for names of keys on a typical keyboard. The carriage-return key, sometimes marked as a bent arrow, enter, or return on the key board, is called <CR>.
GP 25.00	Small letters are used for examples, user input, data output and error messages in text.
	Spaces, as used in the syntax, are entered as spaces.

The **RETURNS** section list the format of the information that the calibrator sends back to the host after receiving the command. The conventions listed above apply.

The **DESCRIPTION** section, provides an overview of the command.

The **EXAMPLES** section list a few examples. When the exact examples are tried on any given system the actual data returned may be different because of system uniqueness.

CHAPTER 5 CONTROL COMMAND GROUP

This group of commands control the operation of the calibrator. The group is divided into three sub groups.

The Read Pressure Group reads the exact pressure that the calibrator is producing or the pressure present at the output connector.

The Set Pressure Group commands the calibrator to produce a preset or negative pressure. It also can command the calibrator to a produce any pressure within the range of the calibrator.

The Initialize Calibrator Group initializes the calibrator or sets it to the zero mode.

The Discrete Output Group controls the operation of the 12 discrete outputs.

The Purge Group commands the calibrator to perform a purge operation.

READ PRESSURE GROUP

These commands read the exact pressure that the calibrator is producing:

- RP - Read calibrator pressure.
- RPA - Read sensor A pressure (dual sensor models only)
- RPB - Read sensor B pressure (dual sensor models only)

READ PRESSURE **[a]RP [/C] < CR >**

SYNTAX

- [a]* - the optional address of the calibrator. Valid symbols are: 1,2,3,4,5,6,7,8,9,U,V,W,X, and Y. Only one is used. If no symbol is entered, address 1 is assumed
- [/C]* - Causes the pressure to be displayed continuously until a <CR> is entered.

RETURNS

press P at *address prompt*

- press* - the pressure in scientific notation.
- address* - the address of the calibrator.
- prompt* - the prompt symbol as set by the set mode (SM) command.

DESCRIPTION

This command displays the current pressure. If the /C option is used the pressure is continuously displayed until a <CR> is entered. Otherwise only one line is displayed.

When the command is completed a prompt is displayed signaling the calibrator is ready to accept the next command.

EXAMPLES

This example displays the pressure one time for calibrator 1.

```
ENTER:      RP <CR>
RETURNS:    -.256799E2 Pat 1
```

This example continuously displays the pressure for calibrator 3. A < CR > stops the display and displays a prompt.

```
ENTER:      3RP/C <CR>
RETURNS:    .154453E2 P at 3
            .154463E2 P at 3
            .154443E2 P at 3
            (Repeats)
ENTER:      <CR>
RETURNS:    >
```

READ PRESSURE A [a]RPA [/C] < CR > (DUAL SENSOR MODELS ONLY)

SYNTAX

- [a] - the optional address of the calibrator. Valid symbols are: 1,2,3,4,5,6,7,8,9,U,V,W,X, and Y. Only one is used. If no symbol is entered, address 1 is assumed
- [/C] - Causes the pressure to be displayed continuously until a < CR > is entered.

RETURNS

press P at *address prompt*

- press* - the pressure in scientific notation.
- address* - the address of the calibrator.
- prompt* - the prompt symbol as set by the set mode (SM) command. Default is the > symbol.

DESCRIPTION

This command displays the current pressure of sensor A for calibrators with dual sensors. This command is used interchangeably with the RP command. If the /C option is used the pressure is continuously displayed until a <CR> is entered. Otherwise only one line is displayed.

When the command is completed a prompt is displayed signaling the calibrator is ready to accept the next command.

EXAMPLES

This example displays the pressure one time for sensor A of calibrator 1

ENTER: RPA <CR>
RETURNS: -.256799E2 AP at 1

This example continuously displays the pressure for sensor A of calibrator 3.

ENTER: 3RPA/C <CR>
RETURNS: .154453E2 AP at 3
.154463E2 AP at 3
.154443E2 AP at 3
(Repeats)
ENTER: <CR>
RETURNS: >

READ PRESSURE B [a]RPB [/C] < CR > (DUAL SENSOR MODELS ONLY)

SYNTAX

- [a] - the optional address of the calibrator. Valid symbols are: 1,2,3,4,5,6,7,8,9,U,V,W,X, and Y. Only one is used. If no symbol is entered, address 1 is assumed
- [/C] - Causes the pressure to be displayed continuously until a < CR > is entered.

RETURNS

press P at *address prompt*

- press* - the pressure in scientific notation.
- address* - the address of the calibrator.
- prompt* - the prompt symbol as set by the set mode (SM) command. Default is the > symbol.

DESCRIPTION

This command displays the current pressure of sensor B for calibrators with dual sensors. This command is used interchangeably with the RP command. If the /C option is used the pressure is continuously displayed until a <CR> is entered. Otherwise only one line is displayed.

When the command is completed a prompt is displayed signaling the calibrator is ready to accept the next command.

EXAMPLES

This example displays the pressure one time for sensor B of calibrator 1

```
ENTER:      RPB <CR>
RETURNS:    - .256799E2 BP at 1
```

This example continuously displays the pressure for sensor B of calibrator 3.

```
ENTER:      3RPB/C <CR>
RETURNS:    .154453E2 BP at 3
            .154463E2 BP at 3
            .154443E2 BP at 3
            (Repeats)
ENTER:      <CR>
RETURNS:    >
```

SET PRESSURE GROUP

These commands instruct the calibrator to produce a pre-set positive, negative or zero pressure:

- PH - Positive High Pressure.
- PM - Positive Medium Pressure.
- PL - Positive Low Pressure.
- NH - Negative High Pressure.
- NM - Negative Medium Pressure.
- NL - Negative Low Pressure.
- GP - A commanded positive pressure.
- GN - A commanded negative pressure.
- ZO - Zero or barometric pressure(depending on the sensor type).

GO POSITIVE **[a]GP value <CR>** **(SERVO CALIBRATOR ONLY)**

SYNTAX

- [a]* - the optional address of the calibrator. Valid symbols are: 1,2,3,4,5,6,7,8,9,U,V,W,X, and Y. Only one is used. If no symbol is entered, address 1 is assumed
- value* - the positive pressure that the calibrator will produce. Value is in decimal, floating point or scientific notation.

RETURNS

prompt

- prompt* - the prompt symbol as set by the set mode (SM) command. Default is the > symbol.

DESCRIPTION

This command causes the calibrator to produce the positive pressure entered in the value field. It also controls the 12 solenoids according to the SCGP configuration variable. For more information on configuration variables refer to the chapter on Configuration Commands.

When the command is completed the prompt is displayed signaling the calibrator is ready to accept the next command.

EXAMPLES

This example sets calibrator 1 to 25.000 psi. The 12 solenoid valves are set according to SCGP configuration variable.

ENTER: GP 25 < CR>
RETURNS: >

This example sets calibrator W to 12.34 psi for The 12 solenoid valves are set according to SCGP configuration variable.

ENTER: WGP 12.34 < CR >
RETURNS: >

This example sets calibrator X to 10.23 psi. The 12 solenoid valves are set according to SCGP configuration variable.

ENTER: XGP . 1023E2 < CR >
RETURNS: >

GO NEGATIVE **[a]GN value <CR>** **(SERVO CALIBRATOR ONLY)**

SYNTAX

[a] - the optional address of the calibrator. Valid symbols are: 1,2,3,4,5,6,7,8,9,U,V,W,X, and Y. Only one is used. If no symbol is entered, address 1 is assumed
value - the negative pressure that the calibrator will produce. Value is in decimal, floating point or scientific notation.

RETURNS

prompt

prompt - the prompt symbol as set by the set mode (SM) command. Default is the > symbol.

DESCRIPTION

This command causes the calibrator to produce the negative pressure entered in the value field by applying a positive pressure to the REF(-) output of the calibrator. It also controls the 12 solenoids according to the SCGN configuration variable. For more information on configuration variables refer to the chapter on Configuration Commands.

When the command is completed the prompt is displayed signaling the calibrator is ready to accept the next command.

EXAMPLES

This example sets calibrator 1 to -25.000 psi. The 12 solenoid valves are set according to SCGN configuration variable.

ENTER: GN 25 < CR>
RETURNS: >

This example sets calibrator W to -12.34 psi for The 12 solenoid valves are set according to SCGN configuration variable.

ENTER: WGN 12.34 < CR >
RETURNS: >

This example sets calibrator X to -10.23 psi. The 12 solenoid valves are set according to SCGN configuration variable.

ENTER: XGN . 1023E2 < CR >
RETURNS: >

POSITIVE HIGH

[a]PH <CR>

SYNTAX

[a] - the optional address of the calibrator. Valid symbols are: 1,2,3,4,5,6,7,8,9,U,V,W,X, and Y. Only one is used. If no symbol is entered, address 1 is assumed

RETURNS

prompt the prompt symbol as set by the set mode (SM) command. Default is the > symbol.

DESCRIPTION

This command causes the calibrator to produce the positive pressure set in the PH configuration variable. It also controls the 12 solenoids according to the SCPH configuration variable. For more information on configuration variables refer to the chapter on Configuration Commands.

When the command is completed a prompt is displayed signaling the calibrator is ready to accept the next command.

EXAMPLES

This example sets the positive pressure of calibrator 1 to the value of the PH configuration variable. If the value of the variable is 100, the pressure output will be 100.

```
ENTER:      PH <CR>
RETURNS:    >
```

POSITIVE MEDIUM

[a]PM <CR>

SYNTAX

[a] - the optional address of the calibrator. Valid symbols are: 1,2,3,4,5,6,7,8,9,U,V,W,X, and Y. Only one is used. If no symbol is entered, address 1 is assumed

RETURNS

prompt the prompt symbol as set by the set mode (SM) command. Default is the > symbol.

DESCRIPTION

This command causes the calibrator to produce the positive pressure set in the PM configuration variable. It also controls the 12 solenoids according to the SCPM configuration variable. For more information on configuration variables refer to the chapter on Configuration Commands.

When the command is completed a prompt is displayed signaling the calibrator is ready to accept the next command.

EXAMPLES

This example sets the positive pressure of calibrator 1 to the value of the PM configuration variable. If the value of the variable is 75, the pressure output will be 75.

```
ENTER:      PM <CR>
RETURNS:    >
```

POSITIVE LOW

[a]PL <CR>

SYNTAX

[a] - the optional address of the calibrator. Valid symbols are: 1,2,3,4,5,6,7,8,9,U,V,W,X, and Y. Only one is used. If no symbol is entered, address 1 is assumed

RETURNS

prompt the prompt symbol as set by the set mode (SM) command. Default is the > symbol.

DESCRIPTION

This command causes the calibrator to produce the positive pressure set in the PL configuration variable. It also controls the 12 solenoids according to the SCPL configuration variable. For more information on configuration variables refer to the chapter on Configuration Commands.

When the command is completed a prompt is displayed signaling the calibrator is ready to accept the next command.

EXAMPLES

This example sets the positive pressure of calibrator 1 to the value of the PL configuration variable. If the value of the variable is 30, the pressure output will be 30.

```
ENTER:          PL <CR>
RETURNS:        >
```

NEGATIVE HIGH

[a]NH <CR>

SYNTAX

[a] - the optional address of the calibrator. Valid symbols are: 1,2,3,4,5,6,7,8,9,U,V,W,X, and Y. Only one is used. If no symbol is entered, address 1 is assumed

RETURNS

prompt the prompt symbol as set by the set mode (SM) command. Default is the > symbol.

DESCRIPTION

This command causes the calibrator to produce the positive pressure set in the NH configuration variable. It also controls the 12 solenoids according to the SCNH configuration variable. For more information on configuration variables refer to the chapter on Configuration Commands.

When the command is completed a prompt is displayed signaling the calibrator is ready to accept the next command.

EXAMPLES

This example sets the positive pressure of calibrator 1 to the value of the NH configuration variable. If the value of the variable is 100, the pressure output will be 100. This pressure will be applied to the REF(-) output of the calibrator.

```
ENTER:          NH <CR>
RETURNS:        >
```

NEGATIVE MEDIUM **[a]NM <CR>**

SYNTAX

[a] - the optional address of the calibrator. Valid symbols are: 1,2,3,4,5,6,7,8,9,U,V,W,X, and Y. Only one is used. If no symbol is entered, address 1 is assumed

RETURNS

prompt the prompt symbol as set by the set mode (SM) command. Default is the > symbol.

DESCRIPTION

This command causes the calibrator to produce the positive pressure set in the NM configuration variable. It also controls the 12 solenoids according to the SCNM configuration variable. For more information on configuration variables refer to the chapter on Configuration Commands.

When the command is completed a prompt is displayed signaling the calibrator is ready to accept the next command.

EXAMPLES

This example sets the positive pressure of calibrator 1 to the value of the NM configuration variable. If the value of the variable is 75, the pressure output will be 75. This pressure will be applied to the REF(-) output of the calibrator.

ENTER: NM <CR>
RETURNS: >

NEGATIVE LOW **[a]NL <CR>**

SYNTAX

[a] - the optional address of the calibrator. Valid symbols are: 1,2,3,4,5,6,7,8,9,U,V,W,X, and Y. Only one is used. If no symbol is entered, address 1 is assumed

RETURNS

prompt the prompt symbol as set by the set mode (SM) command. Default is the > symbol.

DESCRIPTION

This command causes the calibrator to produce the positive pressure set in the NL configuration variable. It also controls the 12 solenoids according to the SCNL configuration variable. For more information on configuration variables refer to the chapter on Configuration Commands.

When the command is completed a prompt is displayed signaling the calibrator is ready to accept the next command.

EXAMPLES

This example sets the positive pressure of calibrator 1 to the value of the NL configuration variable. If the value of the variable is 25, the pressure output will be 25. This pressure will be applied to the REF(-) output of the calibrator.

ENTER: NL<CR>
RETURNS: >

INITIALIZE CALIBRATOR GROUP

This command initializes the calibrator:

- IC - Initialize calibrator.
- Z0 - Zero or Barometric Pressure - Depends upon the sensor type.

INITIALIZE CALIBRATOR [a]IC <CR>

SYNTAX

[a] - the optional address of the calibrator. Valid symbols are: 1,2,3,4,5,6,7,8,9,U,V,W,X, and Y. Only one is used. If no symbol is entered, address 1 is assumed

RETURNS

prompt - the prompt symbol as set by the set mode (SM) command. Default is the > symbol.

DESCRIPTION

This command resets the calibrator to the power up state as set by the SCIC configuration variable. There will be no pressure output.

It also controls the 12 solenoids according to the SCIC configuration variable. For more information on configuration variables see the chapter on Configuration Commands.

When the command is completed a prompt is displayed signaling the calibrator is ready to accept the next command.

EXAMPLES

This example resets Calibrator 1. The 12 solenoid valves are set according to the SCIC configuration variable.

```
ENTER:          IC <CR>
RETURNS:        >
```

This example resets Calibrator 7. The 12 solenoid valves are set according to the SCIC configuration variable.

```
ENTER:          7IC <CR>
RETURNS:        >
```

ZERO PRESSURE

[a]ZO <CR>

SYNTAX

[a] - the optional address of the calibrator. Valid symbols are: 1,2,3,4,5,6,7,8,9,U,V,W,X, and Y. Only one is used. If no symbol is entered, address 1 is assumed

RETURNS

prompt - the prompt symbol as set by the set mode (SM) command. Default is the > symbol.

DESCRIPTION

This command causes the calibrator to produce 0 or barometric pressure depending on the type of sensor.

It also controls the 12 solenoids according to the SCZO configuration variable. For more information on configuration variables see the chapter on Configuration Commands.

When the command is completed a prompt is displayed signaling the calibrator is ready to accept the next command.

EXAMPLES

This example sets the output pressure of Calibrator 1 to 0. If the sensor is a differential transducer, the front panel will display the zero offset. If the sensor is an absolute transducer, the front panel will display ambient pressure. The 12 solenoid valves are set according to SCZO configuration variable.

```
ENTER:          ZO <CR>
RETURNS:        >
```

This example sets the output pressure of Calibrator 7 to 0. If the sensor is a differential transducer, the front panel will display the zero offset. If the sensor is an absolute transducer, the front panel will display ambient pressure. The 12 solenoid valves are set according to SCZO configuration variable.

```
ENTER:          7ZO <CR>
RETURNS:        >
```

DISCRETE OUTPUT GROUP

These commands energize or de-energize any of the 12 discrete outputs:

- EC - Controls any one of the 12 discrete outputs.
- SC - Controls all of the 12 discrete outputs.

ENERGIZE CLOSURE

[a]EC *channel state* < CR >

SYNTAX

[a] - the optional address of the calibrator. Valid symbols are: 1,2,3,4,5,6,7,8,9,U,V,W,X, and Y. Only one is used. If no symbol is entered, address 1 is assumed

channel - the discrete channel number ranging from 1 to 12.

state - Y for on or N for off.

RETURNS

prompt the prompt symbol as set by the set mode (SM) command. Default is the > symbol.

DESCRIPTION

This command sets the discrete closure specified on or off. No other channel is affected. When the command is completed a prompt is displayed signaling the calibrator is ready to accept the next command.

EXAMPLES

This example energizes circuit closure 1 in calibrator 1.

ENTER: EC 1 Y <CR>
RETURNS: >

This example energizes circuit closure 1 in calibrator 2.

ENTER: 2EC 1 N <CR>
RETURNS: >

SET CLOSURE [a]SC *pattern* < CR >

SYNTAX

[a] - the optional address of the calibrator. Valid symbols are: 1,2,3,4,5,6,7,8,9,U,V,W,X, and Y. Only one is used. If no symbol is entered, address 1 is assumed

pattern - the word pattern to control all of the discrete outputs from 1 to 12. The following coding is used:
Y - Turns channel on
N - Turns channel off
X - Leaves channel unchanged

The channel is determined by the position of the Y,N, or X symbol. The following indicated the channel number as related to position is pattern word:

Channel: 1 2 3 4 5 6 7 8 9 10 11 12

RETURNS

prompt - the prompt symbol as set by the set mode (SM) command. Default is the > symbol.

DESCRIPTION

This command sets all the discrete channels, 1 to 12, to either on off or unchanged. When the command is completed a prompt is displayed signaling the calibrator is ready to accept the next command.

EXAMPLES

EXAMPLE 1

ENTER - SC YYYYYXXXNNNN < CR >

RETURNS - >

This example controls the following discrete channels, in calibrator 1, as follows:

1 - ON
2 - ON
3 - ON
4 - ON
5 - Unchanged
6 - Unchanged
7 - Unchanged
8 - Unchanged
9 - OFF
10 - OFF
11 - OFF
12 - OFF

PURGE GROUP

This command conducts a purge operation:

PG - Perform purge.

PURGE

[a]PG <CR>

SYNTAX

[a] - the optional address of the calibrator. Valid symbols are: 1,2,3,4,5,6,7,8,9,U,V,W,X, and Y. Only one is used. If no symbol is entered, address 1 is assumed.

RETURNS

PURGE PREP *seconds* **SEC REMAINING**
PURGE *seconds* **SEC REMAINING**
PURGE EXIT *seconds* **SEC REMAINING**
prompt

The following is returned when an infinite delay is chosen for purge:

PURGE PREP *seconds* SEC REMAINING
PURGE INFINITE DELAY.. <CR> TO EXIT
PURGE EXIT *seconds* **SEC REMAINING**
prompt

prompt - the prompt symbol as set by the set mode (SM) command. Default is the > symbol.

seconds - the time remaining in seconds. The message containing this time is updated every 5 seconds.

DESCRIPTION

This command causes the calibrator to purge the system. Purge has three states, purge preparation, actual purge, and purge exit. During each state the selected discrete outputs are set or reset for a predefined time. Both the discrete output selection and time duration are controlled by configuration variables. See the chapter on Configuration Commands for more information on configuration variables. The following paragraphs explain each state.

The discrete output channels are controlled by the SCPL configuration variable during the purge preparation state. The time that the calibrator remains in the purge preparation state is controlled by the PGD1 configuration variable.

The discrete output channels are controlled by the SCP2 configuration variable during the actual purge state. The time that the calibrator remains in the actual purge state is controlled by the PGD2 configuration variable. The calibrator could remain in the actual purge for an infinite time by setting PGD2 accordingly.

The discrete output channels are controlled by the SCP3 configuration variable during the purge exit state. The time that the calibrator remains in the purge exit state is controlled by the PGD1 configuration variable. This is the same variable that controls the time for the preparation state.

WARNING: It is possible to destroy the pressure transducers by either removing power during the actual purge state or not specifying sufficient time for the purge exit state.

During the purge operation the user is informed of the time remaining in each state. Upon completion of the purge operation, a prompt will be displayed signaling that the calibrator is ready to accept the next command.

EXAMPLES

EXAMPLE 1:

ENTER: PG <CR>

If configuration variables PGD1 and PGD2 are set to 10.0 and 20.0 seconds respectively and purge is commanded, the following will occur:

RETURNS:

```
PURGE PREP 10 SEC REMAINING
PURGE PREP 5 SEC REMAINING
PURGE 20 SEC REMAINING
PURGE 15 SEC REMAINING
PURGE 10 SEC REMAINING
PURGE 5 SEC REMAINING
PURGE EXIT 10 SEC REMAINING
PURGE EXIT 5 SEC REMAINING
>
```

This example:

Sets the discrete outputs according to the SCPL configuration variable for 10 seconds.

Sets the discrete outputs according to SCP2 for 20 seconds.

Sets the discrete outputs according to SCP3 for 10 seconds.

Resets the calibrator.

EXAMPLE 2:

ENTER: PC <CR>

If configuration variables PGD1 is set to 10.0 seconds and PGD2 is set to infinity (FFFFFFFF hex) and purge is commanded, the following will occur:

RETURNS:

```
PURGE PREP 10 SEC REMAINING
PURGE PREP 5 SEC REMAINING
PURGE INFINITE DELAY .. < CR > TO EXIT
```

ENTER:

<CR>

RETURNS:

```
PURGE EXIT 10 SEC REMAINING
PURGE EXIT 5 SEC REMAINING
>
```

This example:

Sets the discrete outputs according to the SCPL configuration variable for 10 seconds.

Sets the discrete outputs according to SCP2 until the user enters a <CR>.

Sets the discrete outputs according to SCP3 for 10 seconds.

Resets the calibrator.

CHAPTER 6 CONFIGURE COMMAND GROUP

This group of commands control the configuration of the calibrator. The calibrator features under control of these commands are: 1-secondary standard pressure transducer type and associated pressure correction, 2-pressure set points, 3-servo control loop constants, 4-discrete outputs control, and 5-other identification items.

In all cases these settings are saved after power is removed.

This command group either sets the calibrator configuration or reads the calibrator configuration. One additional command, burn prom, allows the configuration to be saved after power down.

SET CONFIGURATION

The following commands set the calibrator configuration:

- NC - New Coefficient
- NR - New Ranges
- SM - Set Mode
- SPP - Set Points Positive
- SPN - Set Points Negative
- CSN - Calibrator Serial Number
- SSN - Sensor Serial Number
- MD - Manufacture Date

READ CONFIGURATION

The following commands read the calibration configuration:

- TC - Transmit Coefficients
- SI - Status Inquiry
- DC - Display Coefficients
- DCA - Display A Coefficients
- DCB - Display B Coefficients
- DPP - Display Pressure Points

RETAIN CHANGES

The following command retains changes after power down:

- BP - Burn Prom

CONFIGURATION VARIABLES

Most of the calibrator configuration is handled via configuration variables. These variables are factory set, however, the user may need to change the configuration variables typically due to transducer re-calibration or other system modifications. The user should submit the new configuration variable values to Scanivalve Corp. for our assistance in customer support.

After changing any variable a BP command must be issued to retain the new value after power down.

The two tables, on the following pages, list the configuration variables and their page number by functional group and then in alphabetical order:

PC PRESSURE SENSOR CONFIGURATION

The PC variable controls the type of secondary pressure standard used. Possible values are:

- 1 HEX Single DQ with or without temperature compensation. Configuration for temperature compensation is controlled from the C1, D1 and T01 variables.
- 2 HEX Mensor pressure transduce.
- 3 HEX Dual DQ with or without temperature compensation.
- 4 HEX Dual DQ with or without temperature compensation.

Any other value will prevent the calibrator from reading pressure.

U0 U0 OR X0 COEFFICIENT FOR TEMPERATURE COMPENSATED DQ's

The U0 variable is the U0 or X0 coefficient for a temperature compensated DQ. If dual DQ's are used it pertains to DQ A. This value is provided by the DQ calibration sheet.

Values can range from -16 to +16 decimal. Any value outside this range will produce unpredictable results.

Y1 Y1 COEFFICIENT FOR TEMPERATURE COMPENSATED DQ's

The Y1 variable is the Y1 coefficient for a temperature compensated DO. If dual DQ's are used it pertains to DQ A. This value is supplied by the DQ calibration sheet.

Values can range from -20,000 to +20,000 decimal. Any value outside this range will produce unpredictable results.

Y2 Y2 COEFFICIENT FOR TEMPERATURE COMPENSATED DQ's

The Y2 variable is the Y2 coefficient for as temperature compensated DQ's. If dual DQ's are used it pertains to DQ A.

Values can range from -20,000 to +20,000 decimal. Any value outside this range will produce unpredictable results.

Y3 Y3 COEFFICIENT FOR TEMPERATURE COMPENSATED DQ's

The Y3 variable is the Y3 coefficient for a temperature compensated DQ. If dual DQ's are used it pertains to DQ A.

Values can range from -200,000 to +200,000 decimal. Any value outside this range will produce unpredictable results.

C1 C1 COEFFICIENT FOR TEMPERATURE COMPENSATED DQ's

The C1 variable is the C1 coefficient for a temperature compensated DQ. If dual DQ's are used it pertains to DQ A.

Values can range from -8,000 to +8,000 decimal. Any value outside this range will produce unpredictable results.

C2 C2 COEFFICIENT FOR TEMPERATURE COMPENSATED DQ's

The C2 variable is the C2 coefficient for a temperature compensated DQ. If dual DQ's are used it pertains to DQ A.

Values can range from -1,000 to +1,000 decimal. Any value outside this range will produce unpredictable results.

C3 C3 COEFFICIENT FOR TEMPERATURE COMPENSATED DQ's

The C3 variable is the C3 coefficient for a temperature compensated DQ. If dual DO's are used it pertains to DQ A.

Values can range from -20,000 to 20,000 decimal. Any value outside this range will produce unpredictable results.

D1 D1 COEFFICIENT FOR TEMPERATURE COMPENSATED DQ's

The D1 variable is the D1 coefficient for a temperature compensated DQ. If dual DQ's are used it pertains to DQ A.

Values can range from -200 to 200 decimal. Any value outside this range will produce unpredictable results.

D2 D2 COEFFICIENT FOR TEMPERATURE COMPENSATED DQ's

The D2 variable is the D2 coefficient for a temperature compensated DQ. If dual DQ's are used it pertains to DQ A.

Values can range from -200 to +200 decimal. Any value outside this range will produce unpredictable results.

T1 T1 COEFFICIENT FOR TEMPERATURE COMPENSATED DQ's

The T1 variable is the T1 coefficient for a temperature compensated DQ. If dual DQ's are used it pertains to DQ A.

Values can range from -120 to +120 decimal. Any value outside this range will produce unpredictable results.

T2 T2 COEFFICIENT FOR TEMPERATURE COMPENSATED DQ's

The T2 variable is the T2 coefficient for a temperature compensated DQ. If dual DQ's are used it pertains to DQ A.

Values can range from -120 to +120 decimal. Any value outside this range will produce unpredictable results.

T3 T3 COEFFICIENT FOR TEMPERATURE COMPENSATED DQ's

The T3 variable is the T3 coefficient for a temperature compensated DQ. If dual DQ's are used it pertains to DQ A.

Values can range from -120 to +120 decimal. Any value outside this range will produce unpredictable results.

T4 T4 COEFFICIENT FOR TEMPERATURE COMPENSATED DQ's

The T4 variable is the T4 coefficient for a temperature compensated DQ. If dual DQ's are used it pertains to DQ A.

Values can range from -200 to +200 decimal. Any value outside this range will produce unpredictable results.

T5 T5 COEFFICIENT FOR TEMPERATURE COMPENSATED DQ's

The T5 variable is the T5 coefficient for a temperature compensated DQ. If dual DQ's are used it pertains to DQ A.
Values can range from -2,000 to +2,000 decimal. Any value outside this range will produce unpredictable results.

C1 C COEFFICIENT FOR NON-TEMPERATURE COMPENSATED DQ's

The C1 variable is the C coefficient for a non-temperature compensated DQ. If dual DQ's are used it pertains to DO A.
Values can range from -8,000 to +8,000 decimal. Any value outside this range will produce unpredictable results. **NOTE:** When DO temperature compensation is available and desired C1 must be set to 0 Hexadecimal.

D1 D COEFFICIENT FOR NON-TEMPERATURE COMPENSATED DQ's

The D1 variable is the D coefficient for a non-temperature compensated DQ. If dual DQ's are used it pertains to DQ A.
Values can range from -200 to +200 decimal. Any value outside this range will produce unpredictable results. **NOTE:** When DQ temperature compensation is available and desired D1 must be set to 0 Hexadecimal.

T01 T0 COEFFICIENT FOR NON-TEMPERATURE COMPENSATED DQ's

The T01 variable is the T0 coefficient for a non-temperature compensated DQ. If dual DQ's are used it pertains to DQ A.
Values can range from -120 to +120 decimal. Any value outside this range will produce unpredictable results. **NOTE:** When DQ temperature compensation is available and desired T01 must be set to 0 Hexadecimal.

U0B U0 OR X0 COEFFICIENT FOR TEMPERATURE COMPENSATED DQ B

The U0B variable is the U0 or X0 coefficient for a temperature compensated DO. Used only in dual DO mode and pertains to DO B. This value is provided by the DO calibration sheet.
Values can range from -16.00000000 to 16.00000000 decimal. Any value outside this range will produce unpredictable results.

Y1B Y1 COEFFICIENT FOR TEMPERATURE COMPENSATED DQ B

The Y1B variable is the Y1 coefficient for a temperature compensated DQ. Used only in dual DQ mode and pertains to DQ B.
Values can range from -20,000 to +20,000 decimal. Any value outside this range will produce unpredictable results.

Y2B Y2 COEFFICIENT FOR TEMPERATURE COMPENSATED DQ B

The Y2B variable is the Y2 coefficient for as temperature compensated DQ. Used only in dual DQ mode and pertains to DQ B.
Values can range from -20,000 to +20,000 decimal. Any value outside this range will produce unpredictable results.

Y3B Y3 COEFFICIENT FOR TEMPERATURE COMPENSATED DQ B

The Y3B variable is the Y3 coefficient for a temperature compensated DQ. Used only in dual DQ mode and pertains to DQ B. Values can range from -200,000 to +200,000 decimal. Any value outside this range will produce unpredictable results.

C1B C1 COEFFICIENT FOR TEMPERATURE COMPENSATED DQ B

The C1B variable is the C1 coefficient for a temperature compensated DQ. Used only in dual DQ mode and pertains to DQ B. Values can range from -8,000 to +8,000 decimal. Any value outside this range will produce unpredictable results.

C2B C2 COEFFICIENT FOR TEMPERATURE COMPENSATED DQ B

The C2B variable is the C2 coefficient for a temperature compensated DQ. Used only in dual DQ mode and pertains to DQ B. Values can range from -1,000 to +1,000 decimal. Any value outside this range will produce unpredictable results.

C3B C3 COEFFICIENT FOR TEMPERATURE COMPENSATED DQ B

The C3B variable is the C3 coefficient for a temperature compensated DQ. Used only in dual DQ mode and pertains to DQ B. Values can range from -20,000 to +20,000 decimal. Any value outside this range will produce unpredictable results.

D1B D1 COEFFICIENT FOR TEMPERATURE COMPENSATED DQ B

The D1B variable is the D1 coefficient for a temperature compensated DQ. Used only in dual DQ mode and pertains to DQ B. This value is supplied by the DQ calibration sheet. Values can range from -200.0000000 to 200.0000000 decimal. Any value outside this range will produce unpredictable results.

D2B D2 COEFFICIENT FOR TEMPERATURE COMPENSATED DQ B

The D2B variable is the D2 coefficient for a temperature compensated DQ. Used only in dual DQ mode and pertains to DQ B. Values can range from -200 to 200 decimal. Any value outside this range will produce unpredictable results.

T1B T1 COEFFICIENT FOR TEMPERATURE COMPENSATED DQ B

The T1B variable is the T1 coefficient for a temperature compensated DQ. Used only in dual DQ mode and pertains to DQ B. Values can range from -120 to +120 decimal. Any value outside this range will produce unpredictable results.

T2B T2 COEFFICIENT FOR TEMPERATURE COMPENSATED DQ B

The T2B variable is the T2 coefficient for a temperature compensated DQ. Used only in dual DQ mode and pertains to DQ B. Values can range from -120 to +120 decimal. Any value outside this range will produce unpredictable results.

T3B T3 COEFFICIENT FOR TEMPERATURE COMPENSATED DQ B

The T3B variable is the T3 coefficient for a temperature compensated DQ. Used only in dual DQ mode and pertains to DQ B. Values can range from -120 to +120 decimal. Any value outside this range will produce unpredictable results.

T4B T4 COEFFICIENT FOR TEMPERATURE COMPENSATED DQ B

The T4B variable is the T4 coefficient for a temperature compensated DQ. Used only in dual DQ mode and pertains to DQ B. Values can range from -200 to +200 decimal. Any value outside this range will produce unpredictable results.

T5B T5 COEFFICIENT FOR TEMPERATURE COMPENSATED DQ B

The T5B variable is the T5 coefficient for a temperature compensated DQ. Used only in dual DQ mode and pertains to DQ B. Values can range from -2,000 to +2,000 decimal. Any value outside this range will produce unpredictable results.

C1B C COEFFICIENT FOR NON-TEMPERATURE COMPENSATED DQ B

The C1B variable is the C coefficient for a non-temperature compensated DQ. Used only in dual DQ mode and pertains to DQ B. Values can range from -8,000 to +8,000 decimal. Any value outside this range will produce unpredictable results. **NOTE:** When DQ temperature compensation is available and desired, C1B must be set to 0 Hexadecimal.

D1B D COEFFICIENT FOR NON-TEMPERATURE COMPENSATED DQ B

The D1B variable is the D coefficient for a non-temperature compensated DQ. Used only in dual DQ mode and pertains to DQ B. Values can range from -200 to +200 decimal. Any value outside this range will produce unpredictable results. **NOTE:** When DQ temperature compensation is available and desired, D1B must be set to 0 Hexadecimal.

T01B T0 COEFFICIENT FOR NON-TEMPERATURE COMPENSATED DQ B

The T01B variable is the T0 coefficient for a non-temperature compensated DQ. Used only in dual DQ mode and pertains to DQ B. Values can range from -120 to +120 decimal. Any value outside this range will produce unpredictable results. **NOTE:** When DQ temperature compensation is available and desired, T01B must be set to 0 Hexadecimal.

A A COEFFICIENT FOR MENSOR TRANSDUCER

The A variable is the A coefficient for a Mensor Transducer.
Values can range from -120 to +120.000000 decimal. Any value outside this range will produce unpredictable results.

B B COEFFICIENT FOR MENSOR TRANSDUCER

The B variable is the B coefficient for a Mensor Transducer.
Values can range from -120 to +120 decimal. Any value outside this range will produce unpredictable results.

C C COEFFICIENT FOR MENSOR TRANSDUCER

The C variable is the C coefficient for a Mensor Transducer.
Values can range from -1,000 to +1,000 decimal. Any value outside this range will produce unpredictable results.

D D COEFFICIENT FOR MENSOR TRANSDUCER

The D variable is the D coefficient for a Mensor Transducer.
Values can range from -1,000 to +1,000 decimal. Any value outside this range will produce unpredictable results.

PCC SELECT PRESSURE UNITS

The PCC variable selects the calibration pressure units. To operate the calibrator in the chosen pressure units select the Hexadecimal conversion code from the following table:

PRESSURE UNITS	CONVERSION CODE	CONVERSION RELATIONSHIP
Pounds per Square inch	0/H	1 psi = 1 psi
Atmospheres	1/H	1 psi = 0.068046 A
Bar	2/H	1 psi = 0.068947 b
Centimeters of Mercury	3/H	1 psi = 5.17149 cmHg
Centimeters of Water	4/H	1 psi = 70.308 cmH ₂ O
Decibar	5/H	1 psi = 0.68947db
Feet of Water	6/H	1 psi = 2.3067 ftH ₂ O
Grams per Square Centimeter	7/H	1 psi = 70.306 g/cm ²
Inches of Mercury	8/H	1 psi = 2.036 inHg @ 0EC
Inches of Water	9/H	1 psi = 27.68 inH ₂ O @ 4EC
Kilonewtons per Square Meter	10/H	1 psi = 6.89476 kN/m ²
Kilograms per Square Meter	11/H	1 psi = 703.069 kg/m ²
Kilograms/ Square Centimeter	12/H	1 psi = 0.070307 kg/cm ²
Kilopascals	13/H	1 psi = 6.89476 kPa
Kips per Square Inch	14/H	1 psi = 0.001 kip/in ²
Megapascals	15/H	1 psi = 0.00689476 Mpa
Millibar	16/H	1 psi = 68.497 mb
Meters of Water	17/H	1 psi = 0.70309 mH ₂ O
Millimeters of Mercury	18/H	1 psi = 51.7149 mmHg
Newtons per Square Meter	19/H	1 psi = 6894.76 N/m ²
Newtons / Square Centimeter	20/H	1 psi = 0.689476 N/cm ²
Ounces per Square Inch	21/H	1 psi = 16 oz/in ²
Ounces per Square Foot	22/H	1 psi = 2304 oz/ft ²
Pascals	23/H	1 psi = 6894.76 Pa
Pounds per Square Foot	24/H	1 psi = 144 lb/ft ²
Torr(Millimeters of Mercury)	25/H	1 psi = 51.7149 T
USER CHOSEN	26/H	1 psi = USER CHOSEN

A user may operate in pressure units not listed in the preceding table by setting the PCC configuration variable to 26 HEX and setting the configuration variable PCO to the chosen conversion factor. Refer to the description of the PCO variable for more information.

The following limitations apply when selecting pressure units:

- 1) The chosen pressure units when converted to PSI must not exceed 1,000 psi.
- 2) The chosen pressure units must not exceed 130,000 units or be a negative number.
- 3) A user specified conversion factor, PCO, may not exceed 16,000 and must be positive.

Selecting any conversion code not listed in table will cause the calibrator to use psi units.

NOTE: The modification of the PCC variable must be made according to the procedure in section ZZ

PCO SPECIAL PRESSURE UNITS

The PCO variable holds the conversion factor of any special pressure units not listed in the PCC table.

Values can range from 0 to 16,000 decimal. Any value outside this range will produce unpredictable results. **All** conditions listed in the PCO description apply.

KI SERVO INTEGRAL GAIN

The KI variable holds the integral gain constant for the servo control loop.

Values can range from 0 to 7FFFFFFF HEX. Any value outside of this range will produce unpredictable results. Value selection is affected by pneumatic system dynamics and are beyond the scope of this manual.

KP SERVO PROPORTIONAL GAIN

The KP variable holds the proportional gain constant for the control loop.

Values can range from 0 to 7FFFFFFF HEX. Any value outside of this range will produce unpredictable results. Value selection is affected by pneumatic system dynamics and are beyond the scope of this manual.

REG REGULATOR OR SERVO BASED

The REG variable configures the calibrator software for manual regulators or servo control.

When REG is set to 1 HEX, the software will operate a regulator based calibrator controls pressure.

Any other value configures the calibrator software for a servo calibrator.

SCPH DISCRETE CONTROL FOR POSITIVE HIGH

The SCPH variable holds the encoded value that controls the twelve discrete outputs during the positive high command. These discrete outputs remain either energized or de-energized until another command, that affects the discrete outputs, changes their state.

The possible states of a discrete output are: de-energized, no change from past value, and energized. The control is based on the 32 bit pattern within the variable. Each discrete output is controlled by two bits, a low order and a high order bit, within the variable. To determine which two bits correspond to a particular discrete output, use the following formula:

$$\text{LOW ORDER BIT POSITION} = 2^{(\text{DISCRETE OUTPUT} - 1)}$$

$$\text{HIGH ORDER BIT POSITION} = \text{LOW ORDER BIT POSITION} + 1$$

The least significant bit position is position 0 and the most significant bit position is 23. Bits 24 through 31 are always set to zero.

After the bit positions are found, the bit values are determined from the following table

OUTPUT STATE	HIGH ORDER BIT	LOW ORDER BIT
de-energized	0	0
no change	0	1
no change	1	0
energized	1	1

After the binary pattern is determined for all 12 discrete outputs, the binary word is converted to a hexadecimal word. This becomes the encoded Hexadecimal value used for the variable.

Use the following table to convert the Binary numbers to Hexadecimal:

Binary Number	Hex Number
0000	0
0001	1
0010	2
0011	3
0100	4
0101	5
0110	6
0111	7
1000	8
1001	9
1010	A
1011	B
1100	C
1101	D
1110	E
1111	F

EXAMPLE:

Discrete outputs 1, 2 and 3 are to be energized during positive high command, outputs 4, 5, 6, 7, 8, and 9 should retain their past state, and 10, 11, and 12 should be de-energized. The following table determines the encoding:

Discrete Output	Energized State	Bit Positions	Bit Values	Group of Four	Hexadecimal Digit
1	ON	1, 0	11		
2	ON	3, 2	11	1111	F
3	ON	5, 4	11		
4	NO CHANGE	7, 6	01	0111	7
5	NO CHANGE	9, 8	01		
6	NO CHANGE	11, 10	01	0101	5
7	NO CHANGE	13, 12	01		
8	NO CHANGE	15, 14	01	0101	5
9	NO CHANGE	17, 16	01		
10	OFF	19, 18	00	0001	1
11	OFF	21, 20	00		
12	OFF	23, 22	00	0000	0

From the last column of the table the encoded word for SCPH is 0001557F HEX.

SCPM DISCRETE CONTROL FOR POSITIVE MEDIUM

The SCPM variable holds the encoded Hexadecimal value that controls the discrete outputs during the positive medium command.

For more information on value encoding, refer to the SCPH variable description.

SCPL DISCRETE CONTROL FOR POSITIVE LOW

The SCPL variable holds the encoded Hexadecimal value that controls the discrete outputs during the positive low command.

For more information on value encoding, refer to the SCPH variable description.

SCNH DISCRETE CONTROL FOR NEGATIVE HIGH

The SCNH variable holds the encoded hexadecimal value that controls the discrete outputs during the negative high command.

For more information on value encoding, refer to the SCPH variable description.

SCNM DISCRETE CONTROL FOR NEGATIVE MEDIUM

The SCNH variable holds the encoded hexadecimal value that controls the discrete outputs during the negative medium command.
For more information on value encoding, refer to the SCPH variable description.

SCNL DISCRETE CONTROL FOR NEGATIVE LOW

The SCNL variable holds the encoded hexadecimal value that controls the discrete outputs during the negative low command.
For more information on value encoding, refer to the SCPH variable description.

SCGP DISCRETE CONTROL FOR GO POSITIVE

The SCGP variable holds the encoded hexadecimal value that controls the discrete outputs during the go positive command.
For more information on value encoding, refer to the SCPH variable description.

SCGN DISCRETE CONTROL FOR GO NEGATIVE

The SCGN variable holds the encoded hexadecimal value that controls the discrete outputs during the go negative command.
For more information on value encoding, refer to the SCPH variable description.

SCZO DISCRETE CONTROL FOR ZERO

The SCZO variable holds the encoded hexadecimal value that controls the discrete outputs during the zero command.
For more information on value encoding, refer to the SCPH variable description.

SCIC DISCRETE CONTROL FOR INITIALIZE CALIBRATOR

The SCIC variable holds the encoded hexadecimal value that controls the discrete outputs during the initialize calibrator command.
For more information on value encoding, refer to the SCPH variable description.

SCPU DISCRETE CONTROL FOR POWER UP

The SCPU variable holds the encoded hexadecimal value that controls the discrete outputs immediately after power up.
For more information on value encoding, refer to the SCPH variable description.

SCBH DISCRETE CONTROL FOR HIGH BUTTON

The SCBH variable holds the encoded hexadecimal value that controls the discrete outputs while pressing the high button on regulator based calibrators only.
For more information on value encoding, refer to the SCPH variable description.

SCBM DISCRETE CONTROL FOR MEDIUM BUTTON

The SCBM variable holds the encoded hexadecimal value that controls the discrete outputs while pressing the medium button on regulator based calibrators only.
For more information on value encoding, refer to the SCPH variable description.

SCBL DISCRETE CONTROL FOR LOW BUTTON

The SCBL variable holds the encoded hexadecimal value that controls the discrete outputs while pressing the low button on regulator based calibrators only.
For more information on value encoding, refer to the SCPH variable description.

SCPI DISCRETE CONTROL FOR PREPARE PURGE

The SCPL variable holds the encoded hexadecimal value that controls the discrete outputs during the purge command and prepare purge state.
For more information on value encoding, refer to the SCPH variable description.

SCP2 DISCRETE CONTROL FOR ACTUAL PURGE

The SCP2 variable holds the encoded hexadecimal value that controls the discrete outputs during the purge command and actual purge state.
For more information on value encoding, refer to the SCPH variable description.

SCP3 DISCRETE CONTROL FOR EXIT PURGE

The SCP3 variable holds the encoded hexadecimal value that controls the discrete outputs during the purge command and exit purge state.
For more information on value encoding, refer to the SCPH variable description.

DQPH PRESSURE DQ HIGH LIMIT

The DQPH variable holds the raw count upper limit for the DQ pressure channel. Any raw counts that are above this value will cause a calibrator fault. The scaling of this variable is: 8,000,000 counts = 16 microseconds. Values can range from 0 to 7FFFFFFF HEX. Any value outside this range will produce unpredictable results.

DQPL PRESSURE DQ LOW LIMIT

The DQPL variable holds the raw count lower limit for the DQ pressure channel. Any raw counts that are below this value will cause a calibrator fault. The scaling of this variable is: 8,000,000 counts = 16 microseconds. Values can range from 0 to 7FFFFFFF HEX. Any value outside this range will produce unpredictable results.

DQPH TEMPERATURE DQ HIGH LIMIT

The DQTH variable holds the raw count upper limit for the DQ temperature channel. Any raw counts that are above this value will cause a calibrator fault. The scaling of this variable is: 8,000,000 counts = 16 micro seconds. Values can range from 0 to 7FFFFFFF HEX. Any value outside this range will produce unpredictable results.

DQTL TEMPERATURE DQ LOW LIMIT

The DQTL variable holds the raw count low limit for the DQ temperature channel. Any raw counts that are below this value will cause a calibrator fault. The scaling of this variable is: 8,000,000 counts = 16 micro seconds. Values can range from 0 to 7FFFFFFF HEX. Any value outside this range will produce unpredictable results.

PGD1 PREPARE AND EXIT PURGE TIME

The PGD1 variable holds the time, in seconds, for prepare purge and exit purge. Values can range from 0 to 1,000,000,000 seconds. Values outside this range will produce unpredictable results.

PGD2 ACTUAL PURGE TIME

The PGD2 variable holds the time, in seconds, for actual purge. Values can range from 0 to 1,000,000,000 decimal seconds. One special value: FFFFFFFF HEX, will cause an infinite actual purge time. Values outside this range will produce unpredictable results.

ADDR CALIBRATOR ADDRESS

The ADDR variable holds the calibrator address. The ADDR calibrator address is only used if all four of the address selection hardware jumpers are installed. Otherwise, the calibrator address is set according to the hardware selection jumpers. The address change is effective immediately upon change. Values can range from 0 through 13 which correspond to calibrator addresses 1 through 9, U, V, W, X, and Y respectively. Values outside this range will produce unpredictable results.

MEPH ANALOG SENSOR HIGH LIMIT

The MEPH variable holds the raw count upper limit for the analog pressure sensor. Any raw counts that are above this value will cause a calibrator fault. The scaling of this variable is 0 HEX = -5V, 7FFF HEX = 0V, and FFFF HEX = +5V. Values can range from 0 to FFFF HEX. Any value outside this range will produce unpredictable results.

MEPL ANALOG SENSOR LOW LIMIT

The MEPL variable holds the raw count lower limit for the analog pressure sensor. Any raw counts that are below this value will cause a calibrator fault. The scaling of this variable is 0 HEX = -5V, 7FFF HEX = 0V, and FFFF HEX = +5V. Values can range from 0 to FFFF HEX. Any value outside this range will produce unpredictable results.

SVH SERVO MAXIMUM POSITION

The SVH variable holds the maximum position, in volts, of the servo valve. Values can range from 0 to 32 volts. Any value outside this range will produce unpredictable results.

SVL SERVO MINIMUM POSITION

The SVL variable holds the minimum position, in volts, of the servo valve. Values can range from 0 to 32 decimal volts. Any value outside this range will produce unpredictable results.

CHAN ANALOG SENSOR INPUT CHANNEL

The CHAN variable holds the A/D multiplex channel used for reading the analog pressure sensor. Values can range from 0 to 7 HEX. Any value outside this range will produce unpredictable results.

MESA ANALOG SENSOR AVERAGE

The MESA variable holds the number of times to average the analog sensor's reading. It is expressed as a power of two. The following table lists the possible values:

MESA	NUMBER OF AVERAGES
0 HEX	1 reading
1 HEX	2 readings
2 HEX	4 readings
3 HEX	8 readings
4 HEX	16 readings
5 HEX	32 readings
6 HEX	64 readings

Any value outside the above values will cause the calibrator to use 64 readings. The power must be cycled after issuing a BP command to make a change effective.

MEG ANALOG SENSOR CONVERSION FACTOR

The MEG variable holds the value that software uses to convert A/D counts to voltage. The determination of this value is beyond the scope of this manual.

MEGS ANALOG SENSOR CONVERSION FACTOR SHIFT

The MEGS variable holds the shift amount for the A/D counts to voltage conversion. The determination of this value is beyond the scope of this manual.

The following pages detail the commands from the configuration group.

SET CONFIGURATION

The following commands set the calibrator configuration:

- NC - New Coefficient
- NR - New Ranges
- SM - Set Mode
- SPP - Set Points Positive
- SPN - Set Points Negative
- CSN - Calibrator Serial Number
- SSN - Sensor Serial Number
- MD - Manufacture Date

NEW CONFIGURATION VARIABLES

[a]NC *symbol data* [/H] < CR >

SYNTAX

[a]- the optional address of the calibrator. Valid symbols are: 1,2,3,4,5,6,7,8,9,U,V,W,X, and Y. Only one is used. If no symbol is entered, address 1 is assumed

symbol- one of the configuration variables.

data - either decimal or hexadecimal formatted numbers.

[/H] - Causes the data to interpreted as a hexadecimal value. With no option the numbers are either decimal integer, floating point, or scientific notation.

RETURNS

prompt - the prompt symbol as set by the set mode (SM) command. Default is the > symbol.

DESCRIPTION

This command sets the configuration variable to the value entered. The value is assumed to be hexadecimal if the /H option is used. Otherwise it is assumed to be a decimal value.

WARNING: after setting a configuration variable, a BP command must be issued to retain the new value if the calibrator is powered down.

When the command is completed, a prompt is displayed signaling that the calibrator is ready to accept another command.

EXAMPLES

This example sets the DQ coefficient U0 to 12.6754 in calibrator 1.

```
ENTER:      NC U0 12.6754
RETURNS:    >
```

This example sets the configuration variable PC in calibrator 5 to 34AD hex.

```
ENTER:      5NC PC 34AD /H
RETURNS:    >
```

NEW RANGES **[a]NR *regulator standard* < CR >**

SYNTAX

[a] - the optional address of the calibrator. Valid symbols are: 1, 2, 3, 4, 5, 6, 7, 8, 9, U, V, W, X, and Y. Only one is used. If no symbol is entered, address 1 is assumed

regulator - the new regulator range in the current units (refer to PCC).

standard - the new secondary standard range in the current units (refer to PCC).

RETURNS

prompt - the prompt symbol as set by the set mode (SM) command. Default is the > symbol.

DESCRIPTION

This command allows the entry of the regulator and secondary standard range values. In the servo model, the regulator range value is a safety device used to limit the commanded pressure output. The limit is 1000 psi or 110% of the regulator range value, whichever is less.

When PCC is modified to a value other than PSI, the range and regulator values should be modified to values in the new units.

The standard range value is for information and identification purposes only. Both standard and regulator values are retrieved by the SI command.

To retain this value after power down, a BP command must be issued. When the command is completed a prompt is displayed signaling the calibrator is ready to accept another command.

EXAMPLES

1. This example sets the regulator and secondary standard ranges for calibrator 1 to 5 psi.

```
ENTER:      NR 5 5
RETURNS:    >
```

2. This example sets the regulator and secondary standard ranges for the calibrator in example 1 to equivalent values in kPa

```
ENTER NR 35 35
RETURNS    >
```

SET MODE **[a]SM *pcode echo*< CR >**

SYNTAX

[a] - the optional address of the calibrator. Valid symbols are: 1, 2, 3, 4, 5, 6, 7, 8, 9, U, V, W, X, and Y. Only one is used. If no symbol is entered, address 1 is assumed

pcode- The code number for the desired prompt.
0 = Null prompt record.
1 = <CR> <LF>
2 = <CR> <LF>;
3 = <CR> <LF> >

echo - determines if the incoming characters are echoed back to the host. Coding is as follows:
N - No echo
E - Characters are echoed back to the host

RETURNS

prompt

prompt - the prompt symbol as set by this command. Default is the > symbol.

DESCRIPTION

This command sets the type of prompt that is displayed after each command. It signals the user that the calibrator is ready to accept a new command.

It also determines if incoming characters are echoed back to the host.

For this setting to be retained after power down, a BP command must be issued.

When the command is completed a prompt is displayed signaling the calibrator is ready to accept the next command.

EXAMPLES

This example sets Calibrator 1's prompt to a semicolon with echo enabled.

ENTER: SM 2E
RETURNS: ;

This example sets Calibrator 5's prompt to a null with no echo. Hence, nothing is returned.

ENTER: 5SM 0N
RETURNS:

SET POINTS POSITIVE

[a]SPP *phv pmv plv*< CR >

SYNTAX

[a] - The optional address of the calibrator. Valid symbols are: 1, 2, 3, 4, 5, 6, 7, 8, 9, U, V, W, X, and Y. Only one is used. If no symbol is entered, address 1 is assumed

phv - The positive high pressure set point.

pmv - The positive medium pressure set point.

plv - The positive low pressure set point.

RETURNS

prompt

prompt - The prompt symbol as set by the set mode (SM) command. Default is the > symbol.

DESCRIPTION

This command sets the three preset pressure points. These are the pressures set points to be used when the commands PH, PM, and PL are issued. The pressure units used are those set by the PCC configuration variable.

When the command is completed a prompt is displayed signaling the calibrator is ready to accept another next command.

The new set points take effect upon issuance of this command. To retain the new values after power down, a BP command must be issued.

EXAMPLE

This example sets the positive high, positive medium, and positive low preset pressure points to 30.0, 25.0, and 20.0 respectively. The units are those set by the PCC configuration variable.

```
ENTER:      SPP 30.0 25.0 20.0
RETURNS:    >
```

SET POINTS NEGATIVE **[a]SPN nhv nmv nlv< CR >**

SYNTAX

- [a]* - The optional address of the calibrator. Valid symbols are: 1, 2, 3, 4, 5, 6, 7, 8, 9, U, V, W, X, and Y. Only one is used. If no symbol is entered, address 1 is assumed

- nhv* - The negative high pressure set point.
- nmv* - The negative medium pressure set point.
- nlv* - The negative low pressure set point.

RETURNS

prompt

- prompt - The prompt symbol as set by the set mode (SM) command. Default is the > symbol.

DESCRIPTION

This command sets the three preset pressure points. These are the pressures set points to be used when the commands NH, NM, and NL are issued. The pressure units used are those set by the PCC configuration variable.

When the command is completed a prompt is displayed signaling the calibrator is ready to accept another next command.

The new set points take effect upon issuance of this command. To retain the new values after power down, a BP command must be issued.

EXAMPLE

This example sets the negative high, negative medium, and negative low preset pressure points to 30.0, 25.0, and 20.0 respectively. The units are those set by the PCC configuration variable.

```
ENTER:      SPN 30.0 25.0 20.0
RETURNS:    >
```

CALIBRATOR SERIAL NUMBER [a]CSN ccccccccc<CR>

SYNTAX

[a] - The optional address of the calibrator. Valid symbols are: 1, 2, 3, 4, 5, 6, 7, 8, 9, U, V, W, X, and Y. Only one is used. If no symbol is entered, address 1 is assumed

cccccccc - is up to a 10 alpha-numeric character serial number.

RETURNS

prompt

prompt The prompt symbol as set by the set mode (SM) command. Default is the > symbol.

DESCRIPTION

This command sets the calibrator serial number. The serial number is viewed by the SI command and on power-up.

When the command is completed, a prompt is displayed signaling the calibrator is ready to accept another command.

To retain the new value after power down, a BP command must be issued.

WARNING - This value should not be changed by the user. It is set at the factory for reference.

EXAMPLE

This example sets the calibrator serial number to 123456789A.

ENTER: CSN 123456789A
RETURNS: >

SENSOR SERIAL NUMBER [a]SSN ccccccccc<CR>

SYNTAX

[a] - The optional address of the calibrator. Valid symbols are: 1, 2, 3, 4, 5, 6, 7, 8, 9, U, V, W, X, and Y. Only one is used. If no symbol is entered, address 1 is assumed

cccccccc - is up to a 10 alpha-numeric character serial number.

RETURNS

prompt

prompt The prompt symbol as set by the set mode (SM) command. Default is the > symbol.

DESCRIPTION

This command sets the calibrator serial number. The serial number is viewed by the SI command and on power-up.

When the command is completed, a prompt is displayed signaling the calibrator is ready to accept another command.

To retain the new value after power down, a BP command must be issued.

WARNING - This value should only be changed if a different sensor is installed by the user. It is set at the factory for reference.

EXAMPLE

This example sets the calibrator sensor serial number to 123456789A.

ENTER: CSN 123456789A
RETURNS: >

MANUFACTURE DATE [a]MD *mml*dd(yy<CR>

SYNTAX

- [a]* - The optional address of the calibrator. Valid symbols are: 1, 2, 3, 4, 5, 6, 7, 8, 9, U, V, W, X, and Y. Only one is used. If no symbol is entered, address 1 is assumed
- mm* - A two digit number from 01 to 12 representing the month.
- dd* - A two digit number from 01 to 31 representing the day.
- yy* - A two digit number from 00 to 99 representing the last two digits of the year.

RETURNS

prompt

- prompt - The prompt symbol as set by the set mode (SM) command. Default is the > symbol.

DESCRIPTION

This command sets the manufacture date of the calibrator. It is viewed by the SI command and on power-up.

When the command is completed a prompt is displayed signaling the calibrator is ready to accept another command.

To retain the new value after power down, a BP command must be issued.

WARNING - This value should not be changed by the user. It is set at the factory for reference.

EXAMPLE

This example sets the calibrator's manufacture date to January 19, 1996.

```
ENTER:      MD 01/19/96
RETURNS:    >
```

READ CONFIGURATION

The following commands read the calibration configuration:

- TC - Transmit Coefficients
- SI - Status Inquiry
- DC - Display Coefficients
- DCA - Display A Coefficients
- DCB - Display B Coefficients
- DPP - Display Pressure Points

TRANSMIT CONFIGURATION VARIABLE

[a]TC *symbol* [/HI <CR>

SYNTAX

[a]- the optional address of the calibrator. Valid symbols are: 1,2,3,4,5,6,7,8,9,U,V,W,X, and Y. Only one is used. If no symbol is entered, address 1 is assumed

symbol - is one of the configuration variables symbols.

[/HI - Causes the data to displayed as a hexadecimal value. With no option the numbers are displayed in decimal.

RETURNS

value prompt

value - the value of the symbol in either hexadecimal or decimal.

prompt - the prompt symbol as set by the set mode (SM) command. Default s the > symbol.

DESCRIPTION

This command displays the configuration variable data. The data is displayed in decimal unless the hex option is used.

When the command is completed a prompt is displayed signaling the calibrator is ready to accept the next command.

EXAMPLES

This example displays the DQ coefficient, configuration variable, for calibrator 1.

```
ENTER:      TC U0
RETURNS:    U0 = +.3456E2
```

This example displays the configuration variable PC for calibrator 5 in hexadecimal..

```
ENTER:      5NC PC /H
RETURNS:    PC = 00000001
```

STATUS INQUIRY

[a]SI < CR >

SYNTAX

[a]- the optional address of the calibrator. Valid symbols are: 1, 2, 3, 4, 5, 6, 7, 8, 9, U, V, W, X, and Y. Only one is used. If no symbol is entered, address 1 is assumed

RETURNS

ZOC Calibration Module *address*

VER *v. w* **Copyright © Scanivalve Corp. 1992.**

xxxx psi regulator, yyyy psi sensor

Calibrator serial number *nnnnnnnnnn*

Sensor serial number *ssssssssss* **Manufacture date** *mmlddlyy*

prompt

<i>address</i> -	the calibrator address
<i>v.w</i> -	the calibrator software version
<i>xxxx</i> -	the regulator range set by the NR command
<i>yyyy</i> -	the sensor pressure range set by the NR command.
<i>nnnnnnnnnnnn</i> -	the calibrator serial number
<i>ssssssssssss</i> -	the secondary transducer serial number
<i>mmlddlyy</i> -	the manufacturing date
<i>prompt</i> -	the prompt symbol as set by the set mode (SM) command. Default is the > symbol.

DESCRIPTION

This command displays information about the calibrator.

When the command is completed a prompt is displayed signaling the calibrator is ready to accept another command.

DISPLAY CONFIGURATION VARIABLES

[a]DC [/H]<CR>

SYNTAX

- [a] - the optional address of the calibrator. Valid symbols are: 1, 2, 3, 4, 5, 6, 7, 8, 9, U, V, W, X, and Y. Only one is used. If no symbol is entered, address 1 is assumed
- [/H] - Causes the data to be displayed as a hexadecimal value. With no option the numbers are displayed in decimal

RETURNS

```
cn = cv      cn = cv      cn = cv
cn = cv      cn = cv      cn = cv
%o  %o      %o  %o      %o  %o
cn = cv      cn = cv      cn = cv
prompt
```

- cn* - The name of the configuration variable.
- cv* - The value of the configuration variable. If the /H option is used the value is displayed in hexadecimal, otherwise it is displayed in decimal.
- prompt* - The prompt symbol as set by the set mode (SM) command. Default is the > symbol.

This command requires a full screen of 25 lines to display all variables.

DESCRIPTION

This command transmits all of the configuration variable names and their values in either hexadecimal or decimal form. When dual DQ's are used this command displays all variables, except those associated with DQ B.

EXAMPLES

This command displays all the data in decimal form.

```
ENTER:      DC
RETURNS:    U0=3.5678E002      Y1=4.5678E001      Y2=5.678E-002
              Y3=3.5345E002      T0=3.5678E003      T1=4.678E-001
              %o  %o          %o  %o          %o  %o/%o
              PC=0.0E001        PH=2.5678E002      PL=1.678E001
              >
```

This command displays all the data in hexadecimal form

```
ENTER:      DC/H
RETURNS:    U0=01234ABC      Y1=23ADC234      Y2=5ADC2221
              Y3=A3245698      T0=39876542      T1=9A321456
              %o  %o          %o  %o          %o  %o
              PC=89765432      PH=321AADC3      PL=3456789A
```

DISPLAY CONFIGURATION VARIABLES A

[a]DCA [/H] < CR >

SYNTAX

[a] - the optional address of the calibrator. Valid symbols are: 1, 2, 3, 4, 5, 6, 7, 8, 9, U, V, W, X, and Y. Only one is used. If no symbol is entered, address 1 is assumed

[/H] - Causes the data to be displayed as a hexadecimal value. With no option the numbers are displayed in decimal notation.

RETURNS

```
cn = cv      cn = cv      cn = cv
cn = cv      cn = cv      cn = cv
%o           %o           %o           %o
cn = cv      cn = cv      cn = cv
prompt
```

cn - The name of the configuration variable.

cv - The value of the configuration variable. If the /H option is used the value is displayed in hexadecimal, otherwise it is displayed in decimal.

prompt - The prompt symbol as set by the set mode (SM) command. Default is the > symbol.

Please note that this command requires a full screen of 25 lines to display all variables.

DESCRIPTION

This command transmits all of the configuration variable names and their values in either hexadecimal or decimal form. When dual DQ's are used this command displays all variables, except those associated with DQ B. This command is identical to the DC command.

EXAMPLES

This command displays all the data in decimal form.

```
ENTER:      DCA
RETURNS:    U0=3.5678E002      Y1=4.5678E001      Y2=5.678E-002
            Y3=3.5345E002      T0=3.5678E003      T1=4.678E-001
            %o           %o           %o           %o
            PC=0.0E001          PH=2.5678E002      PL=1.678E001
            >
```

This command displays all the data in hexadecimal form

```
ENTER:      DCA/H
RETURNS:    U0=01234ABC      Y1=23ADC234      Y2=5ADC2221
            Y3=A3245698      T0=39876542      T1=9A321456
            %o           %o           %o           %o
            PC=89765432      PH=321AADC3      PL=3456789A
```

DISPLAY CONFIGURATION VARIABLES B

[a]DCB [/H] < CR >

SYNTAX

[a] - the optional address of the calibrator. Valid symbols are: 1, 2, 3, 4, 5, 6, 7, 8, 9, U, V, W, X, and Y. Only one is used. If no symbol is entered, address 1 is assumed

[/H] - Causes the data to be displayed as a hexadecimal value. With no option the numbers are displayed in decimal notation.

RETURNS

```
cn = cv      cn = cv      cn = cv  
cn = cv      cn = cv      cn = cv  
%o      %o      %o      %o      %o      %o  
cn = cv      cn = cv      cn = cv  
prompt
```

cn - The name of the configuration variable.

cv - The value of the configuration variable. If the /H option is used the value is displayed in hexadecimal, otherwise it is displayed in decimal.

prompt - The prompt symbol as set by the set mode (SM) command. Default is the > symbol.

Please note that this command requires a full screen of 25 lines to display all variables.

DESCRIPTION

This command transmits all of the configuration variable names and their values in either hexadecimal or decimal form. When dual DQ's are used this command displays all variables, except those associated with DQ A. This command is identical to the DC command.

EXAMPLES

This command displays all the data in decimal form.

```
ENTER:      DCB  
RETURNS:    U0=3.5678E002      Y1=4.5678E001      Y2=5.678E-002  
            Y3=3.5345E002      T0=3.5678E003      T1=4.678E-001  
            %o      %o      %o      %o      %o      %o  
            PC=0.0E001      PH=2.5678E002      PL=1.678E001  
>
```

This command displays all the data in hexadecimal form

```
ENTER:      DCB/H  
RETURNS:    U0=01234ABC      Y1=23ADC234      Y2=5ADC2221  
            Y3=A3245698      T0=39876542      T1=9A321456  
            %o      %o      %o      %o      %o      %o  
            PC=89765432      PH=321AADC3 PL=3456789A
```

DISPLAY PRESSURE POINTS

[a]DPP < CR >

SYNTAX

[a] - The optional address of the calibrator. Valid symbols are: 1, 2, 3, 4, 5, 6, 7, 8, 9, U, V, W, X, and Y. Only one is used. If no symbol is entered, address 1 is assumed

RETURNS

PH = phv *PM = pmv* *PL = plv*
NH = nhv *NM = nmv* *NL = nlv*
prompt

phv - The positive high pressure set point.
pmv - The positive medium pressure set point.
plv - The positive low pressure set point.
nhv - The negative high pressure set point.
nmv - The negative medium pressure set point.
nlv - The negative low pressure set point.
prompt - The prompt symbol as set by the set mode (SM) command. Default is the > symbol.

DESCRIPTION

This command transmits all of the pressure set points in the chosen pressure units.

EXAMPLE

ENTER: DPP
RETURNS: PH=.30000E2 PM=.25000E2 PL=.15000E2
 NH=.30000E2 NM=.25000E2 NL=.15000E2

RETAIN CHANGES

The following command retains changes after power down:

BP - Burn Prom

BURN PROM

[a]BP<CR>

SYNTAX

[a] - the optional address of the calibrator. Valid symbols are: 1,2,3,4,5,6,7,8,9,U,V,W,X, and Y. Only one is used. If no symbol is entered, address 1 is assumed

RETURNS

prompt

prompt - the prompt symbol as set by the set mode (SM) command. Default is the > symbol.

DESCRIPTION

This command causes the calibrator to retain all of the changed values entered by the NC, NR, SM, SPP, SPN, CSN, SSN, and MD commands after power down.

When the command is completed a prompt is displayed signaling the calibrator is ready to accept another next command.

EXAMPLES

This example retains all modified coefficients after power down for calibrator 1

```
ENTER:      BPP
RETURNS:    >
```

This example retains all modified coefficients after power down for calibrator 5.

```
ENTER:      5BP
RETURNS:    >
```

DIAGNOSTIC COMMAND GROUP

This group of calibrator commands assists in system and calibrator troubleshooting.

The following is a list of these commands:

DMEM	Display the contents of a memory location.
SMEM	Set the contents of a memory location.
DPORT	Display the value of an input port.
SPORT	Set the value of an output port.
DAD	Display the value of an A/D mux channel.
EFLT	Erase any system faults.
DFLT	Display any system faults.
RV	Read the voltage of the analog sensor.
DP	Display the period of the DO sensor
DPA	Display the period of the DO A sensor (dual DO model)
DPB	Display the period of the DO B sensor (dual DO model)

Use of DMEM, SMEM, DPORT, SPORT, and DAD command assumes knowledge of Intel microprocessors and the calibrator design.

DISPLAY MEMORY NAME **[a]DMEM** *seg offset [/B,/W,/L] < CR >*

SYNTAX

- [a] - The optional address of the calibrator. Valid symbols are: 1, 2, 3, 4, 5, 6, 7, 8, 9, U, V, W, X, and Y. Only one is used. If no symbol is entered, address 1 is assumed

- seg* - The segment portion of the memory location. It must be a 16 bit wide hex value (ie. 13AD). Together the segment and offset specify the memory location.

- offset* - The offset portion of the memory location. It must be a 16 bit hex value (ie. E34A). Together the segment and offset specify the memory location displayed.

- [/B,/W,/L]* - The optional size of the memory location displayed. Only one may be used.
 - /B - Byte sized data, 8 bits
 - /W - Word sized data, 16 bits. This is the default if no option is entered.
 - /L - Long sized data, 32 bits.

RETURNS

seg: offset= data

- seg* - The segment specified in the command.

- offset* - The offset specified in the command.

- data* - The hex data at the *seg:offset* memory location. The data displayed is determined by the option listed below.
 - /B - 2 hex digits.
 - /N - 4 hex digits.
 - /L - 8 hex digits.

DESCRIPTION

This command continuously displays the data at the memory location specified. The data continues to display until a <CR> is received. A prompt will then be displayed signaling the calibrator is ready to accept the next command. The data is shown continuously so that changes can be seen.

EXAMPLE

This example continuously displays the long data at memory location 0041:1234, until a <CR> is entered. Calibrator 2 is addressed.

```
ENTER:      2DMFM 41 1234 /L < CR >
RETURNS:    0041:1234=00034A89
            0041:1234=00034A89
            0041:1234=00034A89
ENTER:      <CR>
RETURNS:    >
```

SET MEMORY **[a]SMEM** *seg offset data [B,/W,/L] < CR >*

SYNTAX

- [a] - The optional address of the calibrator. Valid symbols are: 1, 2, 3, 4, 5, 6, 7, 8, 9, U, V, W, X, and Y. Only one is used. If no symbol is entered, address 1 is assumed

- seg* - The segment portion of the memory location. It must be a 16 bit hex value (ie. 13AD). Together the segment and offset specify the memory location.

- offset* - The offset portion of the memory location. It must be a 16 bit hex value (ie. E34A). Together the segment and offset specify the memory location.

- data* - The hex data to be set in the memory location specified by the *seg:offset*.

- [/B,/W,/L] - The optional size of the memory location set. Only one is used. The following are the meaning of each:
 - /B - Byte sized data, 8 bits.
 - /W - Word sized data, 16 bits. This is the default if no option is entered.
 - /L - Long sized data, 32 bits.

RETURNS

prompt

- prompt* - The prompt symbol as set by the set mode (SM) command. Default is the > symbol.

DESCRIPTION

This command sets the data to the memory location specified. A prompt will then be displayed signaling the calibrator is ready to accept the next command. There is no guarantee that the data entered will remain unaltered. In some cases the program will immediately overwrite the data entered.

EXAMPLE

This example sets memory location 41:1234 to 3AA99876. Only one long sized data is set. Calibrator 1 is addressed.

```
ENTER:            SMEM 41 1234 3AA99876 /L < CR >
RETURNS:         >
```

DISPLAY PORT **[a]DPORT** *port* [/B,/W] < CR >

SYNTAX

[a] - The optional address of the calibrator. Valid symbols are: 1, 2, 3, 4, 5, 6, 7, 8, 9, U, V, W, X, and Y. Only one is used. If no symbol is entered, address 1 is assumed

port - The port address. It must be a 16 bit hex value (ie. 13AD).

[/B,/W] - The optional size of the memory location displayed. Only one is used. The following are the meaning of each:

/B - Byte sized data, 8 bits.

/W - Word sized data, 16 bits. This The default if no option is entered.

RETURNS

port= data

port - The port address specified in the command.

data - The hex data at the port address memory location. The width of the data displayed is determined by the option and listed below.

/B - 2 hex digits.

/W - 4 hex digits.

DESCRIPTION

This command continuously displays the data at the port address specified. The data continues to display until a <CR> is received. A prompt will then be displayed signaling the calibrator is ready to accept the next command. The data is shown continuously so that changes can be seen.

EXAMPLE

This example continuously displays the byte data at port address 21 hex until a <CR> is entered. Calibrator 4 is addressed.

ENTER: 4DPORT 21/B<CR>

RETURNS: 0021=00

 0021 =00

 0021 =00

ENTER: <CR>

RETURNS: >

SET PORT **[a]SPORT** *port data [/B,/W] < CR >*

SYNTAX

[a] - The optional address of the calibrator. Valid symbols are: 1, 2, 3, 4, 5, 6, 7, 8, 9, U, V, W, X, and Y. Only one is used. If no symbol is entered, address 1 is assumed

port - The port address. It must be a 16 bit hex value (ie. 13AD).

data - The hex data to be set in the memory location specified by the port.

[/B,/W] - The optional size of the memory location set. Only one is used. The following are the meaning of each:

 /B - Byte sized data, 8 bits.

 /W - Word sized data, 16 bits. This is the default.

RETURNS

prompt

prompt - The prompt symbol as set by the set mode (SM) command. Default is the > symbol.

DESCRIPTION

This command sets the data to the port address specified. A prompt will then be displayed signaling the calibrator is ready to accept the next command.

There is no guarantee that the data entered will remain unaltered. In some cases the program will immediately overwrite the data entered.

EXAMPLE

This example sets port location 23 to 2223. Only one word sized port location is set. Calibrator 1 is addressed.

ENTER: SPORT 23 2223 < CR >

RETURNS: >

DISPLAY A/D **[a]DAD mux<CR>** (MENSOR ONLY)

SYNTAX

[a] - The optional address of the calibrator. Valid symbols are: 1, 2, 3, 4, 5, 6, 7, 8, 9, U, V, W, X, and Y. Only one is used. If no symbol is entered, address 1 is assumed

mux - The mux channel to be displayed. Valid numbers are 0, 1, 2, 3, 4, 5, 6, and 7.

RETURNS

mux= data

mux - The mux channel specified in the command.

data - The hex data from the A/D at the mux channel specified. The width of the data displayed is 16 bits.

DESCRIPTION

This command continuously displays the A/D data at the mux channel specified. The data continues to display until a <CR> is received. A prompt will then be displayed signaling the calibrator is ready to accept the next command. The data is shown continuously so that changes can be seen.

EXAMPLES

This example continuously displays the data from the A/D, mux channel 7 until a <CR> is entered. Calibrator 1 is addressed.

```
ENTER:        DAD7<CR>
RETURNS:     7=1122
              7=1122
              7=1122
ENTER:        <CR>
RETURNS:     >
```

ERASE FAULTS **[a]EFLT<CR>**

SYNTAX

[a] - The optional address of the calibrator. Valid symbols are: 1, 2, 3, 4, 5, 6, 7, 8, 9, U, V, W, X, and Y. Only one is used. If no symbol is entered, address 1 is assumed

RETURNS

prompt

prompt - The prompt symbol as set by the set mode (SM) command. Default is the > symbol.

DESCRIPTION

This command erases any faults that have accumulated since power up. The system severity level is reset to 0.

When the command is complete a prompt is displayed signaling the calibrator is ready to accept the next command.

EXAMPLE

This example erases faults in calibrator 1.

ENTER: EFLT < CR >
RETURNS: >

DISPLAY FAULTS [a]DFLT < CR >

SYNTAX

[a] - The optional address of the calibrator. Valid symbols are: 1, 2, 3, 4, 5, 6, 7, 8, 9 U, V, W, X, and Y. Only one is used. If no symbol is entered, address 1 is assumed

RETURNS

SYSTEM SEVERITY LEVEL *ss/*

FAULT LIST:

fd SEV = *fs* LIMIT = A COUNTS = *fc* SEQ = *sn*

fd SEV = *fs* LIMIT = *fi* COUNTS = *fc* SEQ = *sn*

END OF FAULT LIST

prompt

ss/ - Either a 0, or a 1. A 0 indicates that the current faults will not affect the performance of the calibrator. A 1 indicates that the performance of the calibrator is affected.

fd - The fault description.

fs - The severity level of the particular fault. It is either a 1 or a 0. The system severity level is set based on this number.

fi - The number of consecutive times the fault must occur before being considered valid.

fc - The number of consecutive time the fault occurred. The maximum that can be recorded is 255.

sn - The order, relative to the other faults, that the fault occurred.

prompt The prompt symbol as set by the set mode (SM) command. Default is the > symbol.

DESCRIPTION

This command display the current system severity level and any faults that currently exist along with information about that fault. If no faults exist, a severity level of 0 is displayed with an empty fault list.

When the command is complete a prompt is displayed signaling the calibrator is ready to accept the next command. The list of possible faults are as follows:

"Temperature DQ no start"	"NVM not initialized"
"Temperature DQ timeout"	"Bad interrupt"
"Low press from DQ"	"NVM write timed out"
"High press from DQ"	"Bad UART vector"
"Low temp from DQ"	"UART transmit B interrupt"
"High temp from DQ"	"Temperature DQ B timeout"
"Low temp from DQ B"	"Mensor pressure low"
"High temp from DQ B"	"Mensor pressure high"
"Low press from DQ B"	"A/D timed out"
"High press from DQ B"	"Divide by zero"
"Spare 1"	"4.5 Volt ref high"
"Spare 2"	"4.5 Volt ref low"

EXAMPLES

This example indicates that the system severity level is 0 and that no faults exist in calibrator 1

```
ENTER DFLT<CR>
RETURNS:  SYSTEM SEVERITY LEVEL - > 0
          FAULT LIST:
          END OF FAULT LIST
```

This example indicated that the system severity level in calibrator 4 is 1 and calibrator performance is affected. The existing fault is "." This fault has a severity level of 1 which caused the system severity level to be 1. It takes 5 consecutive counts for this fault to be considered valid. The fault occurred 255 times, well above the 5 times required to be considered valid. It was the first to occur since power up or the issuance of an EFLT command.

```
ENTER:    4DFLT < CR >
RETURNS:  SYSTEM SEVERITY LEVEL - > 1
          FAULT LIST:
          4.5 Volt ref High SEV =001 LIMIT=0005 COUNTS=255 SEQ= 1
          END OF FAULT LIST
```

READ VOLTAGE [a]RV /C<CR> (MENSOR ONLY)

SYNTAX

- [a] - The optional address of the calibrator. Valid symbols are: 1, 2, 3, 4, 5, 6, 7, 8, 9 U, V, W, X, and Y. Only one is used. If no symbol is entered, address 1 is assumed
- [/C] - Causes the voltage output of the pressure transducer to be displayed continuously until a <CR> is entered.

RETURNS

value prompt

value - The voltage output of the Mensor pressure transducer. The value is displayed in scientific notation.

prompt - The prompt symbol as set by the set mode (SM) command. Default is the > symbol.

DESCRIPTION

This command displays the voltage output of the pressure transducer in scientific notation. If the /C option is chosen, the voltage output is displayed continuously until a <CR> is received. When the command is completed a prompt is displayed signaling the calibrator is ready to accept the next command.

This command displays an error if a Digiquartz transducer is installed because it produces a frequency output rather than a voltage output. See the "DP" command.

EXAMPLE

This example displays the transducer voltage one time for calibrator 1.

```
ENTER:      RV<CR>
RETURNS:    .4345E1 V at 1
```

This example continuously displays the transducer voltage for calibrator 5. A <CR> stops the display and displays a prompt.

```
ENTER:      5RV /C<CR>
RETURNS:    .300 V at 5
            .301 V at 5
            .299 V at 5
```

```
ENTER:      <CR>
RETURNS:    >
```

DISPLAY PERIOD [a]DP [/C] <CR> (DIGIQUARTZ ONLY)

SYNTAX

- [a] - The optional address of the calibrator. Valid symbols are: 1, 2, 3, 4, 5, 6, 7, 8, 9 U, V, W, X, and Y. Only one is used. If no symbol is entered, address 1 is assumed
- [/C] - Causes the pressure/temperature periods to be displayed continuously until a <CR> is entered.

RETURNS

PRESS *press* Fs **TEMP** *temp* Fs *prompt*

press - The pressure period of the DQ transducer in microseconds.

temp - The temperature period of the DQ transducer in microseconds. Zero is displayed if the DQ model does not have temperature compensation

prompt - The prompt symbol as set by the set mode (SM) command. Default is the > symbol.

DESCRIPTION

This command displays the pressure and temperature period of the DQ transducer in microseconds. If the /C option is used the values are continuously displayed until a <CR> is received. Otherwise only one line is displayed.

When the command is completed a prompt is displayed signaling the calibrator is ready to accept the next command.

This command displays an error if Mensor pressure transducers are installed because they produce voltage outputs rather than a frequency output. Refer to the "RV" command for more information.

EXAMPLES

This example displays the transducer pressure and temperature one time for calibrator 1.

```
ENTER:      DP<CR>
RETURNS:    PRESS.254453E2 Fs TEMP.5432E1 Fs
```

This example continuously displays the DQ pressure and temperature period for calibrator 3. Note that the temperature period is 0. This indicates that this particular transducer does not have a temperature correction. A <CR> stops the display and displays a prompt.

```
ENTER:      3DP/C<CR>
RETURNS:    PRESS .254453E2 Fs TEMP 0E0 Fs
            PRESS .254463E2 Fs TEMP 0E0 Fs
            PRESS .254443E2 Fs TEMP 0E0 Fs

ENTER:      <CR>
RETURNS:    >
```

DISPLAY PERIOD A [a]DPA [/C] <CR> (DUAL DIGIQUARTZ ONLY)

SYNTAX

- [a] - The optional address of the calibrator. Valid symbols are: 1, 2, 3, 4, 5, 6, 7, 8, 9 U, V, W, X, and Y. Only one is used. If no symbol is entered, address 1 is assumed
- [/C] - Causes the pressure/temperature periods to be displayed continuously until a <CR> is entered.

RETURNS

PRESS *press* Fs **TEMP** *temp* Fs *prompt*

press - The pressure period of the DQ transducer in microseconds.

temp - The temperature period of the DQ transducer in microseconds. Zero is displayed if the DQ model does not have temperature compensation

prompt - The prompt symbol as set by the set mode (SM) command. Default is the > symbol.

DESCRIPTION

This command displays the pressure and temperature period of the DQ transducer in microseconds. If the /C option is used the values are continuously displayed until a <CR> is received. Otherwise only one line is displayed.

When the command is completed a prompt is displayed signaling the calibrator is ready to accept the next command.

This command displays an error if Mensor pressure transducers are installed because they produce voltage outputs rather than a frequency output. Refer to the "RV" command for more information.

EXAMPLES

This example displays the transducer pressure and temperature one time for calibrator 1.

```
ENTER:      DPA<CR>
RETURNS:    PRESS.254453E2 Fs TEMP.5432E1 Fs
```

This example continuously displays the DQ pressure and temperature period for calibrator 3. Note that the temperature period is 0. This indicates that this particular transducer does not have a temperature correction. A <CR> stops the display and displays a prompt.

```
ENTER:      3DPA/C<CR>
RETURNS:    PRESS .254453E2 Fs TEMP 0E0 Fs
            PRESS .254463E2 Fs TEMP 0E0 Fs
            PRESS .254443E2 Fs TEMP 0E0 Fs

ENTER:      <CR>
RETURNS:    >
```

DISPLAY PERIOD B [a]DPB [/C] <CR> (DUAL DIGIQUARTZ ONLY)

SYNTAX

- [a] - The optional address of the calibrator. Valid symbols are: 1, 2, 3, 4, 5, 6, 7, 8, 9 U, V, W, X, and Y. Only one is used. If no symbol is entered, address 1 is assumed
- [/C] - Causes the pressure/temperature periods to be displayed continuously until a <CR> is entered.

RETURNS

PRESS *press* Fs **TEMP** *temp* Fs *prompt*

press - The pressure period of the DQ transducer in microseconds.

temp - The temperature period of the DQ transducer in microseconds. Zero is displayed if the DQ model does not have temperature compensation

prompt - The prompt symbol as set by the set mode (SM) command. Default is the > symbol.

DESCRIPTION

This command displays the pressure and temperature period of the DQ transducer in microseconds. If the /C option is used the values are continuously displayed until a <CR> is received. Otherwise only one line is displayed.

When the command is completed a prompt is displayed signaling the calibrator is ready to accept the next command.

This command displays an error if Mensor pressure transducers are installed because they produce voltage outputs rather than a frequency output. Refer to the "RV" command for more information.

EXAMPLES

This example displays the transducer pressure and temperature one time for calibrator 1.

```
ENTER:      DPB<CR>
RETURNS:    PRESS.254453E2 Fs TEMP.5432E1 Fs
```

This example continuously displays the DQ pressure and temperature period for calibrator 3. Note that the temperature period is 0. This indicates that this particular transducer does not have a temperature correction. A <CR> stops the display and displays a prompt.

```
ENTER:      3DPB/C<CR>
RETURNS:    PRESS .254453E2 Fs TEMP 0E0 Fs
            PRESS .254463E2 Fs TEMP 0E0 Fs
            PRESS .254443E2 Fs TEMP 0E0 Fs

ENTER:      <CR>
RETURNS:    >
```

CALIBRATION UNIT MAINTENANCE

Regular calibrator maintenance requires recalibration of the calibrator pressure transducer at six month intervals unless trend analysis shows that the calibration interval can safely be extended to one year. The calibration interval should not be extended beyond one year.

All of the following procedures require commands to be sent to the calibrator. The syntax and method of issuing commands to a calibrator depends upon the type of calibrator and the system. If the calibrator is connected to a HyScan 1000 or 2000 system, refer to the system manual for instructions on direct calibrator communication. Communication to a calibrator may also be accomplished by using a communication software package such as PROCOMM.

NOTE: The correct calibrator address must precede any command issued to a calibrator(Refer to the Calibrator Operation Section - Chapter 4, for more information). .

TEST EQUIPMENT REQUIRED

An Air Dead Weight Tester accurate to $\pm 0.01\%$ of reading is required.

CALIBRATION SYSTEMS WITH DIGIQUARTZ TRANSDUCERS

When the calibrator module is equipped with a Digiquartz pressure transducer the unit should be tested to determine if the unit is within specification. If the device is not within specification the unit may be recalibrated using the DQCAL program. This program is available from Scanivalve Corp. Contact Scanivalve Corp, Product Support Department for a copy of this program.

TEST PROCEDURE

- 1) Apply power to the calibrator module and allow it to stabilize, in the position it will be used, for a minimum of 4 hours.
- 2) Perform all of the leak tests listed in Chapter 9.
- 3) Apply solenoid control pressure (90-120 psi) to the solenoid supply port. Regulator supply pressure is not required.
- 4) Choose ten calibration pressures in equal increments from zero to full scale.
- 5) Initialize the Calibrator (IC).
Type: [a]IC<enter>
- 6) Read and record the zero or barometric pressure.
Type: [a]RP<enter>
- 7) Apply a calibration pressure from the dead weight tester to the reference port on the calibrator rear panel and record the value.

- 8) When the pressure is stable, issue a Read Pressure (RP) command and record the pressure value.
- 9) Repeat steps 7 and 8 for all ten calibration pressures.
- 10) Subtract the applied pressure from the measured pressure value. Divide the result by the full scale value of the pressure transducer and multiply the result by 100. If any point differs from the applied pressure by more than $\pm 0.01\%$ of Full Scale, the transducer must be re-calibrated.
- 11) Reconnect all pressures and communication lines.

CALIBRATION SYSTEMS WITH MENSOR TRANSDUCERS

Although the Mensor secondary standard pressure transducer is the major component requiring re-calibration, most accurate results are obtained if a complete end-to-end re-calibration is performed. This approach also compensates for any arithmetic errors, and A/D converter errors. The calibrator supports end-to-end calibration by providing a Read Voltage (RV) command.

Because the calibrator uses psi units internally, all calibrations must be performed in psi units. Conversion to other units is handled by changing the PCC configuration variable.

TEST PROCEDURE

- 1) Apply power to the calibrator module and allow it to stabilize, in the position it will be used, for a minimum of 4 hours. The calibrator module must be calibrated in the physical orientation in which it will be used to insure a successful calibration.
- 2) Insure that the temperature remains constant within 2 degrees F for the duration of the calibration procedure.
- 3) Make a record of the existing transducer coefficients A, B, C, and D values.
- 4) Perform all of the leak tests, listed in Chapter 9.
- 5) Apply solenoid control pressure (90-120 psi) to the solenoid supply port. Regulator supply pressure is not required.
- 6) Choose ten calibration pressure in equal increments from zero to full scale.
- 7) Initialize the Calibrator
Type: [a]IC<enter>
- 8) Issue an Energize Closure (EC 6 Y) command.
Type: [a]EC 6 Y<enter>
- 9) Issue a Read Voltage (RV) command and record the voltage. This is the zero pressure reading. Repeat this command a few times to insure that the reading has reached stability.

- 10) Apply a calibration pressure from the dead weight tester to the reference port on the calibrator rear panel and record.
- 11) After insuring that the pressure is stable, issue a Read Voltage (RV) command and record the voltage. Repeat this command a few times to insure that the reading has reached stability.
- 12) Repeat steps 10 and 11 for all ten calibration pressures. If other command is inadvertently selected, steps 7 through 11 must be re-executed to prevent faulty voltage readings due to trapped pressures.
- 13) Generate the new A, B, C, and D coefficients via the MCAL utility program. For more information on using the MCAL program see the chapter on Software Utilities.
- 14) The new coefficients are loaded into the calibrator's EEPROM via the NC command and saved using the BP command.
- 15) Reconnect all pressures and communication lines and cycle calibrator power.

CALIBRATION SYSTEM DIAGNOSTICS

The most common problem in the calibration system are pneumatic leaks. Typical symptoms include unstable calibration pressures and/or channels that cannot be calibrated.

The calibration module was designed so that comprehensive leak tests could be conducted by executing a minimum number of commands.

All of the following procedures require commands to be sent to the calibrator. The syntax and method of issuing commands to a calibrator depends upon the type of calibrator and the system. If the calibrator is connected to a HyScan 1000 or 2000 system, refer to the system manual for instructions on direct calibrator communication. Communication to the calibrator could also be accomplished by using a communication software package such as PROCMM.

NOTE: The correct calibrator address must precede any command issued to a calibrator(Refer to the Calibrator Operation Section, Chapter 4, for more information).

TRANSDUCER LEAK TEST

ABSOLUTE SECONDARY PRESSURE STANDARD

This procedure will test the plumbing and valves adjacent the secondary pressure standard, the standard itself, and the pressure relief valve. See drawing no. 16202 sheet 1 at rear of this manual.

- 1) Cap the CAL(+) fitting on the rear panel for this test.
- 2) Initialize the Calibrator (IC).
Type: IC<enter>
- 3) Issue a Positive High (PH) command. This connects the secondary pressure standard to calibration manifold. It disconnects the secondary pressure standard from reference manifold and applies high pressure to CAL manifold.
- 4) Wait until the system is charged.
- 5) Isolate the secondary pressure standard.
Type: [a]EC 4 N<enter>
- 6) Shut off the calibration pressure.
Type: [a]EC 1 N<enter>
- 6) Wait until the system stabilizes.
- 7) Read the Pressure.
Type: [a]RP<enter>
Record this value as P1
- 8) Wait 10 minutes.

9) Read the Pressure
Type: [a]RP<enter>
Record this value as P2

10) Compute the leak rate per minute as follows:

$$\frac{P1 - P2}{PSIA_{FS}} \times 100 = \text{LeakRate}_{\%/minute}$$

11) The Leak Rate must be less than 1% per minute. If the leak rate is too high, check the relief valve and the input fittings to the transducer

CALIBRATION SYSTEM LEAK TEST

This procedure will leak test the plumbing and valves of the calibration manifold or any modules connected to the CAL(+) fitting on the rear panel.

TEST PROCEDURE

- 1) To test the calibration manifold only, disconnect the pressure line connected to the CAL+ output and cap the fitting (Refer to drawing no. 16202, sheet 1, at the rear of this manual).
- 2) Initialize the Calibrator.
Type: [a]IC<enter>
- 2) Issue a Positive High (PH) command.
Type: [a]PH<enter> This connects the secondary pressure standard to the calibration manifold, disconnects the secondary pressure standard from the reference manifold, and applies the high calibration pressure to the calibration manifold.
- 3) Wait until the system is charged.
- 4) Shut off the pressure input to the calibration manifold
Type: [a]EC 7 Y<enter>
- 5) Trap the high calibration pressure.
Type: [a]EC 1 N<enter>
- 6) Wait for the system to stabilize.
- 7) Read the Pressure
Type: [a]RP<enter>
Record this value as P1.
- 8) Wait 10 minutes.
- 9) Read the Pressure.
Type: [a]RP<enter>
Record this value as P2.
- 10) Compute the leak rate per minute as follows:

$$\frac{P1 - P2}{PSIA_{FS}} \times 100 = \text{Leak Rate}_{\%/minute}$$

- 11) The Leak Rate must be less than 1% per minute.

REFERENCE SYSTEM LEAK TEST

This procedure will leak test the plumbing and valves of the reference manifold or any instrument attached to the REF(-) fitting on the rear panel.

TEST PROCEDURE

- 1) To test the reference manifold only, disconnect the pressure line connected to the REF-output and cap the fitting (Refer to drawing no. 16202, sheet 1, at the rear of this manual).
- 2) Initialize the Calibrator.
Type: [a]IC<enter>
- 2) Issue a Negative High (NH) command.
Type: [a]NH<enter> This connects the secondary pressure standard to the reference manifold, disconnects tunnel static from the reference manifold, and applies the high calibration pressure to the reference manifold.
- 3) Wait until the system is charged.
- 4) Shut off the pressure input to the reference manifold
Type: [a]EC 1 N<enter>
- 6) Wait for the system to stabilize.
- 7) Read the Pressure
Type: [a]RP<enter>
Record this value as P1.
- 8) Wait 10 minutes.
- 9) Read the Pressure.
Type: [a]RP<enter>
Record this value as P2.
- 10) Compute the leak rate per minute as follows:

$$\frac{P1 - P2}{PSIA_{FS}} \times 100 = LeakRate_{\%/minute}$$

- 11) The LeakRate must be less than 1% per minute.

REGULATOR MANIFOLD LEAK TEST

This procedure will leak test the regulator manifold and the reference manifold as one trapped volume.

TEST PROCEDURE

- 1) To test the reference manifold only, disconnect the pressure line connected to the REF-output and cap the fitting (Refer to drawing no. 16202, sheet 1, at the rear of this manual).
- 2) Initialize the Calibrator.
Type: [a]IC<enter>
- 2) Issue a Negative High (NH) command.
Type: [a]NH<enter> This connects the secondary pressure standard to the reference manifold, disconnects tunnel static from the reference manifold, and applies the high calibration pressure to the reference manifold.
- 3) Wait until the system is charged.
- 4) Shut off the pressure input to the reference manifold
Type: [a]EC 1 N<enter>
- 6) Wait for the system to stabilize.
- 7) Read the Pressure
Type: [a]RP<enter>
Record this value as P1.
- 8) Wait 10 minutes.
- 9) Read the Pressure.
Type: [a]RP<enter>
Record this value as P2.
- 10) Compute the leak rate per minute as follows:

$$\frac{P1 - P2}{PSIA_{FS}} \times 100 = LeakRate_{\%/minute}$$

- 11) The LeakRate must be less than 1% per minute.

SOFTWARE UTILITIES

Utility programs are written in DOS and supplied on a 3½" floppy disk.

MCAL MENSOR COEFFICIENT PROGRAM

INTRODUCTION

The 'MCAL' program is used to compute coefficients for a Mensor Secondary Standard from data collected during a calibration. This program will prompt for the values of calibration points and measured voltage. After all of the data has been entered, the calculated coefficients will be displayed.

OPERATION

- 1) Insert the MCAL distribution diskette into a floppy drive log onto that drive and type: MCAL
- 2) Enter the Mensor serial number and pressure range.
- 3) Choose the voltage measurement option. True voltage is defined as the actual output of the Mensor standard. Select NO if the calibration is an end-to-end calibration.
- 4) Enter each applied pressure and output voltage.
- 5) Enter -1 to terminate data entry.
- 6) All pressures and voltages will be displayed. Enter the number of any data point to be changed. To continue, enter -1.
- 7) All data input are displayed. The A, B, and C coefficients and the percent deviation for each data point are displayed. If the deviation of any point is 0.01%, or greater, an error message is displayed. If the fitted curve has a non-linearity of 0.02%, or greater, an error message will be displayed. If an error message is displayed, check all data for accuracy.

DQCAL DIGIQUARTZ COEFFICIENT PROGRAM

INTRODUCTION

The "DQCAL" program is used to compute a modified set of coefficients for a Paroscientific Secondary Standard from data collected during a calibration. This program is provided by Paroscientific. Program documentation and instructions are in a separate booklet. This program is the property of Paroscientific and may not be distributed without their permission.

SPC 2000/2500/3000 SOFTWARE VERSIONS

This list provides information for the current released versions of calibrator software.

Version 1.21B Release date 10/26/93

Current Configuration for CALMOD 2000 Regulator based Calibrators

Version 1.25C Release date 6/06/94

Current Configuration for SPC2500 Calibrators with Dual Digiquartz Secondary Pressure Standards

Version 1.39 Release date 2/08/95

Current Configuration for all other SPC2500 and all SPC3000 Calibrators