

MACU2

MODULE ADDRESS AND CONTROL UNIT

Instruction and Service Manual

1722 North Madison Street
Liberty Lake, WA 99019
Tel: (800) 936-6161
(509) 891-9870
Fax: (509) 891-9481
web site: www.scanivalve.com
e-mail: scanicu@scanivalve.com

Scanivalve Corp.



Table of Contents

- SPECIFICATIONS 1
- INTRODUCTION 2
- INSTALLATION 3
 - Front Panel 4
 - Rear Panel 4
- POWER REQUIREMENTS 5
- ELECTRICAL INPUTS 6
- ELECTRICAL OUTPUTS 7
- THEORY OF OPERATION 8
 - INPUTS 8
 - STEP 8
 - HOME 8
 - OUTPUTS 8
 - ZOC MODULE ADDRESS OUT 8
 - USER SYSTEM ADDRESS OUT 8
 - DISPLAY 8
- USER PROGRAMMING 9
- JUMPERS and DIP SWITCHES 9
- ELECTRICAL SCHEMATICS 11
- EXPLODED VIEW OF THE MACU2 16

Tables and Illustrations

Figure 1 - Installation of MACU's into MACU2	3
Figure 2 - Front Panel	4
Figure 3 - Rear Panel	4
Figure 4 - Power Input Connector	5
Figure 5 - Step/Home Input Connector	6
Figure 6 - ZOC Module Address Output	7
Figure 7 - USER System Address Output	7
Figure 8 - MACU2 Logic Board Layout	10
Figure 9 - MACU2 Logic Board - Part 1	11
Figure 10 - MACU2 Logic Board - Part 2	12
Figure 11 - MACU2 Logic Board - Part 3	13
Figure 12 - MACU2 Logic Board - Part 4	14
Figure 13 - MACU2 Address Display Board	15
Figure 14 - MACU2 - Exploded View	16

SPECIFICATIONS

Operating Temperature	0EC to 55EC
Humidity	95%
Altitude	up to 15,000 feet
Step Rate	up to 50,000 Hz
Home Output	00 or 01, user selectable
Output Code	BCD or BINARY, user selectable
Drive Capacity	16 Modules
Input	STEP and HOME, differential TTL level
Power Requirements	+28 Vdc \pm 8.0 Vdc
Input Connectors	Power: Bendix PT06A-8-3S-SR Step/Home: Bendix PT06CE12-10S
Output Connectors	ZOC Module Address: Bendix PT06CE12-10P USER Address: Bendix PT06CE12-10P
Dimensions	8 in x 9.1 in x 2 in (203mm x 231mm x 51mm)
Weight	2.6 lbs (1190g)

INTRODUCTION

This manual describes the operation, installation and maintenance of the MACU2 Module Address and Control Unit. This unit is capable of addressing up to 16 ZOC Electronic Pressure Scanners. Each MACU2 contains a digital display to indicate the addressed channel, a digital output to a data system to indicate the address output, and address lines to drive all ZOC Electronic Pressure Scanners.

The MACU2 requires 24 to 32 Vdc for operation. This voltage may be interrupted for up to 200 msec without a loss of function.

The MACU2 has been tested for shock, vibration and crash impact. For more details, contact Scanivalve Corporation, Product Support Department.

Front Panel

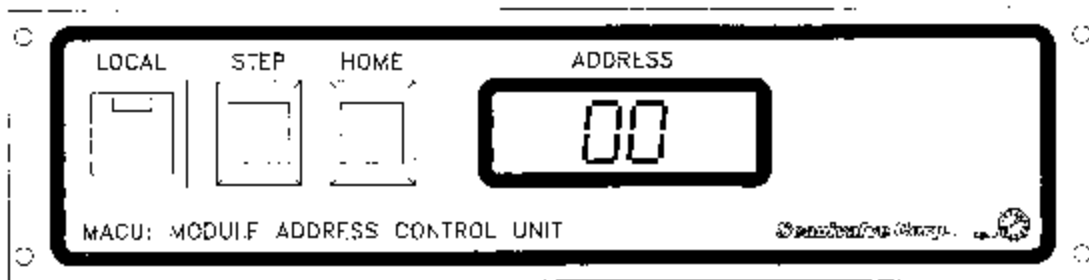

Figure 2 - Front Panel

Rear Panel

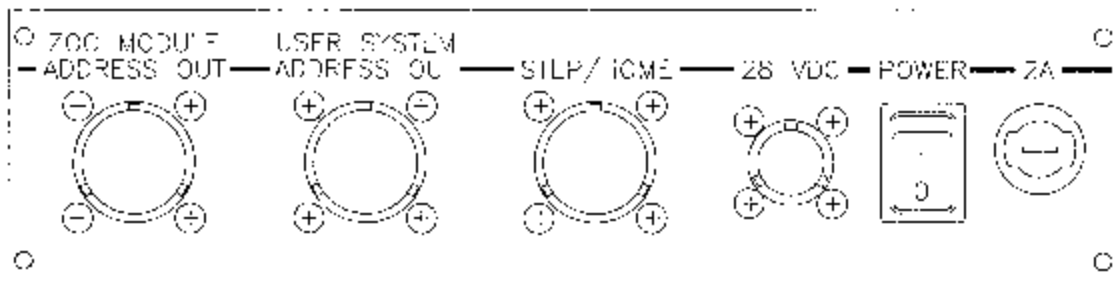

Figure 3 - Rear Panel

POWER REQUIREMENTS

The MACU2 is designed to operate at 28 ± 8 Vdc. The MACU will tolerate a power interruption of 200 ms or more with no change in the operational status. The power input connector is a Bendix PT02A-3S-SR. Figure 4 shows the input wiring.

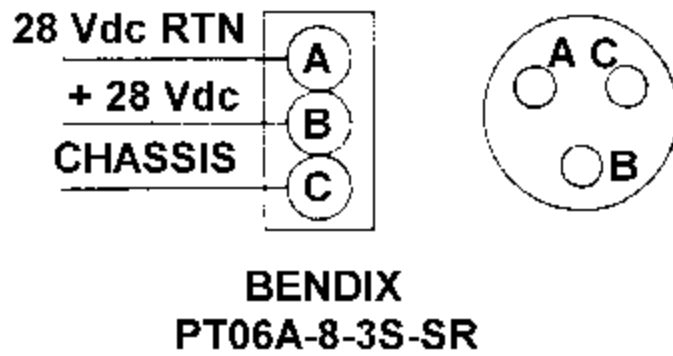

Figure 4 - Power Input Connector

ELECTRICAL INPUTS

The MACU2 has two electrical inputs: **STEP** and **HOME**. These inputs are differential inputs. **HOME** resets the module address to 0 or 1 depending upon the setting of the Home dip switch. **STEP** is used to increment the module address output. This output will reset the address counter when the maximum channel limit is reached. Channel limit may be set by the user to match the modules. Figure 5 shows the wiring of the Step/Home Input connector.

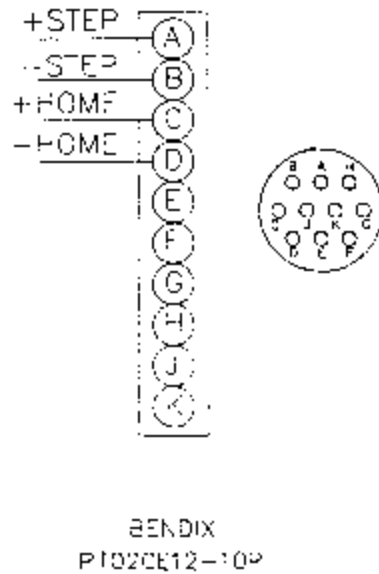

Figure 5 - Step/Home Input Connector

ELECTRICAL OUTPUTS

The MACU2 has two electrical outputs: **ZOC Module Address Out** and **USER System Address Out**. **ZOC Module Address Out** is the address select for the ZOC modules. This address selects the module channel to be read by the user system. All modules connected to the MACU2 will address the same channel. Figure 6 shows the Pinouts of the **ZOC Module Address Output**. **USER System Address Out** provides an address output to the user's data system. Figure 7 shows the Pinouts of the **USER System Address Output**.

NOTE: The output connectors are the same part numbers. The user MUST be careful so as not to connect the outputs incorrectly.

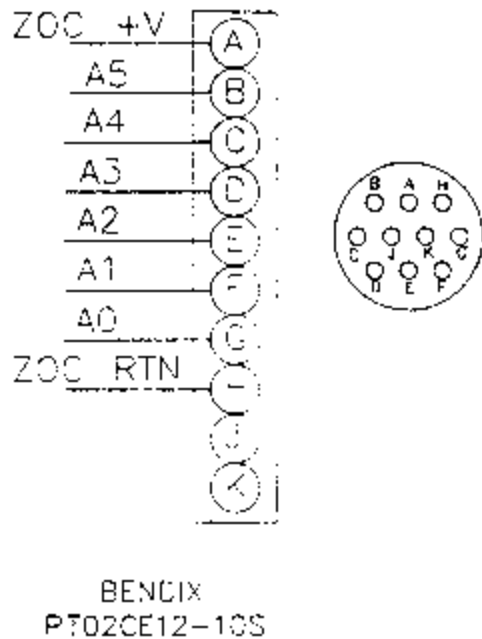

Figure 6 - ZOC Module Address Output

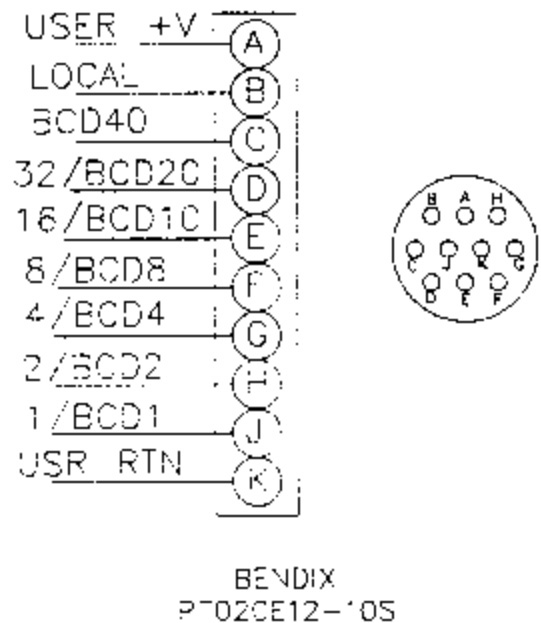

Figure 7 - USER System Address Output

THEORY OF OPERATION

The MACU2 is designed to drive up to 16 ZOC Electronic Pressure Scanners. A single binary channel address is output to all ZOC modules. This address determines which channel will be selected to be monitored. The address is incremented by the **STEP** input. This address may be reset to "Home"(channel 1) by the **HOME** input. The MACU2 may be used with any ZOC Electronic Pressure Scanners. The MACU2 is capable of scanning the channels at speeds up to 50 kHz with minimum cable lengths. The MACU2 is capable of driving Electronic Pressure Scanners located up to 250 ft away, although maximum scanning speeds may be reduced due to cable losses.

The MACU2 may be operated in the Local or Remote mode. The mode may only be switched from the front panel.

INPUTS

STEP

Step is a differential TTL level input that will increment the module address output by one each time a pulse is input. The input trigger level is set with W5. This input is buffered with a photo Darlington transistor.

HOME

Home is a differential TTL level input that will reset the module address output to zero(Channel 1) each time a pulse is input. The input trigger level is set with W6. This input is buffered with a photo Darlington transistor.

OUTPUTS

ZOC MODULE ADDRESS OUT

This address is a CMOS level output to the ZOC Electronic Pressure Scanners. This address will be incremented each time a STEP input is received. It will automatically reset when the maximum channel limit is reached. This address may also be reset by the HOME input.

USER SYSTEM ADDRESS OUT

This address is a TTL level output for the controlling system. It will match the ZOC MODULE ADDRESS OUT. This output may be programmed for Binary or BCD. The polarity of this output may also be set to match the User requirements.

DISPLAY

The front panel has a two digit display to identify the current channel address. Leading zeros may be suppressed.

USER PROGRAMMING

The MACU2 contains two DIP switches, **SW1** and **SW2**, that must be programmed by the user. The setting of these switches control the front panel display, home position indication, maximum channel number, and the type and polarity of the user system output. In addition, there are 6 jumpers which determine the grounding and input levels.

NOTE: Default conditions are shown in **BOLD**.

The Value of Maximum Channel is equal to 1 plus the decimal value of N1-N3 times eight. The maximum value is 64.

JUMPERS and DIP SWITCHES

SWITCH/JUMPER	CONDITION	VALUE
SW1-1	ON	Home = 0
SW1-1	OFF	Home = 1
SW1-2	ON	Display Leading Zeros
SW1-2	OFF	Suppress Leading Zeros
SW2-1	N0	Max Channel bit 0
SW2-2	N1	Max Channel bit 1
SW2-3	N2	Max Channel bit 2
SW2-4	ON	Addr Out = Binary
SW2-4	OFF	Addr Out = BCD
SW2-5	ON	Addr Out = HIGH TRUE
SW2-5	OFF	Addr Out = LOW TRUE
W1	1-2(Front)	Internal Addr Voltage
W1	2-3(Back)	User Addr Voltage
W2	ON	Internal Addr Gnd
W2	OFF	User Addr Gnd
W3	1-2 (Front)	Internal Logic Pull-Up
W3	2-3 (Back)	User Logic Pull-Up
W4	ON	Internal Logic Gnd
W4	OFF	User Logic Gnd
W5	ON	Pulse In = STEP
W5	OFF	No Pulse = STEP
W6	ON	Pulse In = HOME
W6	OFF	No Pulse = HOME

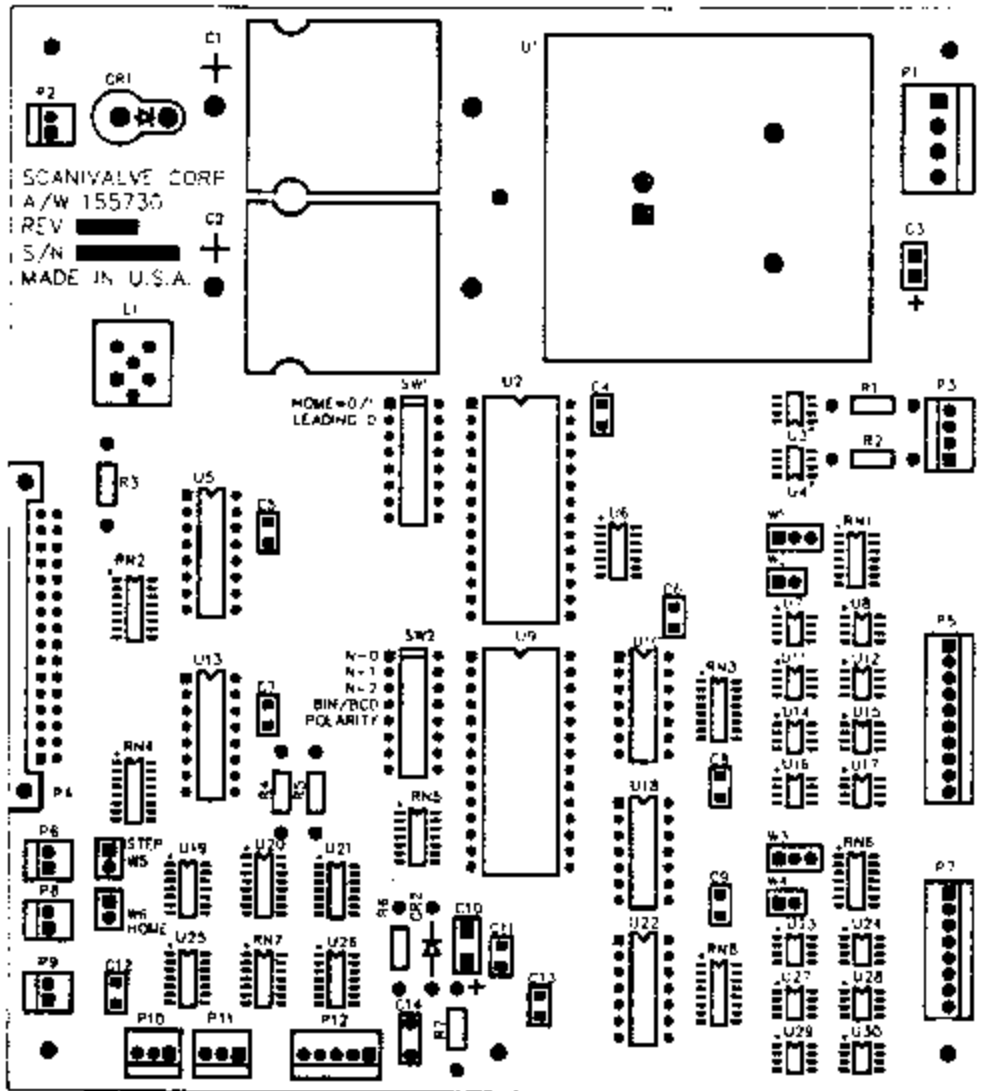

Figure 8 - MACU2 Logic Board Layout

ELECTRICAL SCHEMATICS

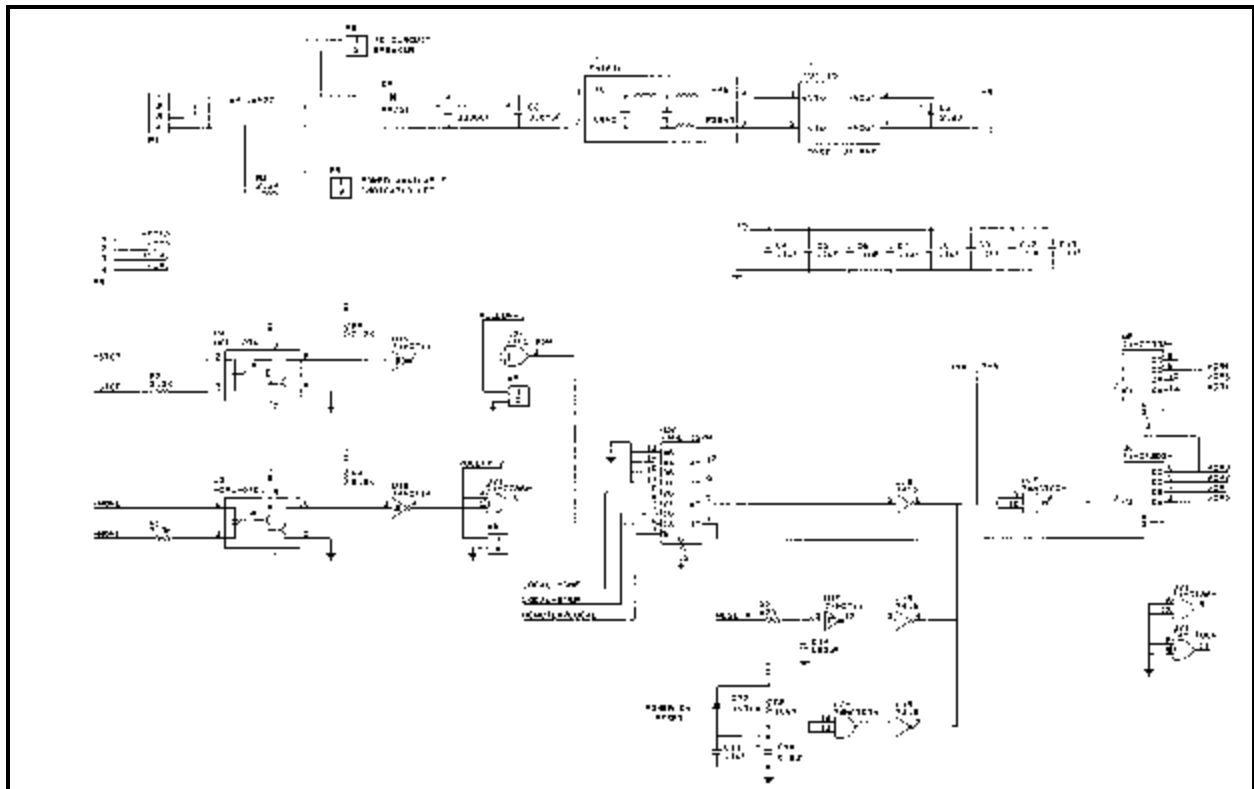

Figure 9 - MACU2 Logic Board - Part 1

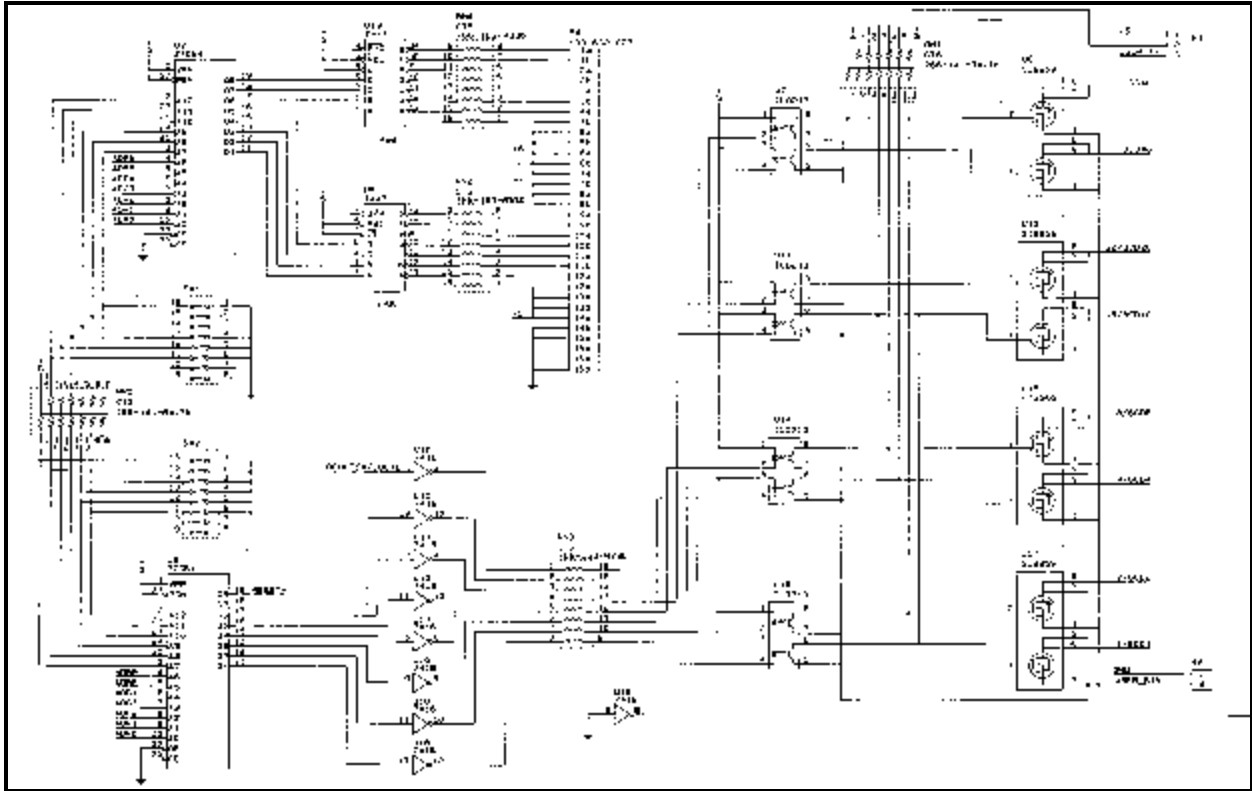

Figure 10 - MACU2 Logic Board - Part 2

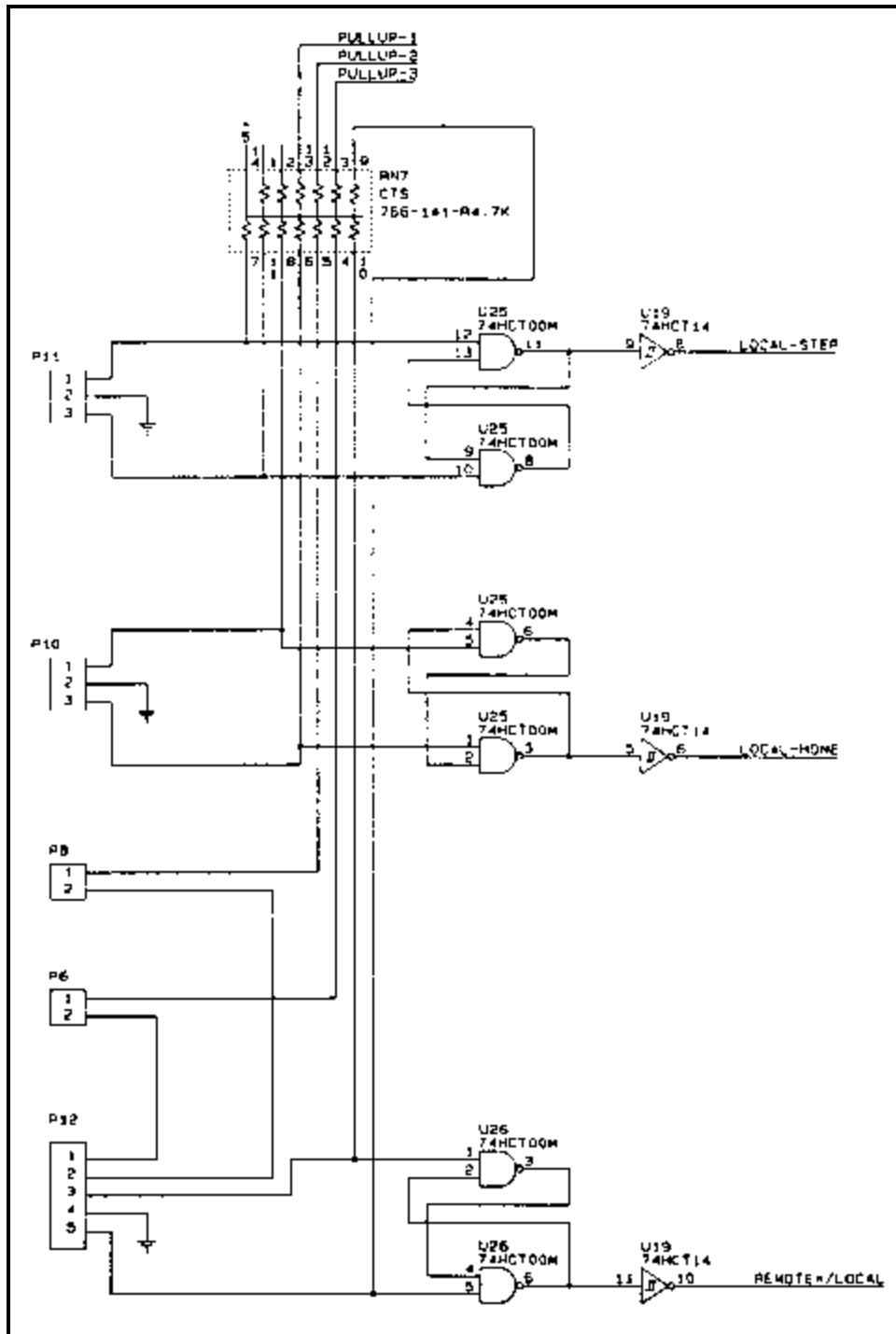

Figure 11 - MACU2 Logic Board - Part 3

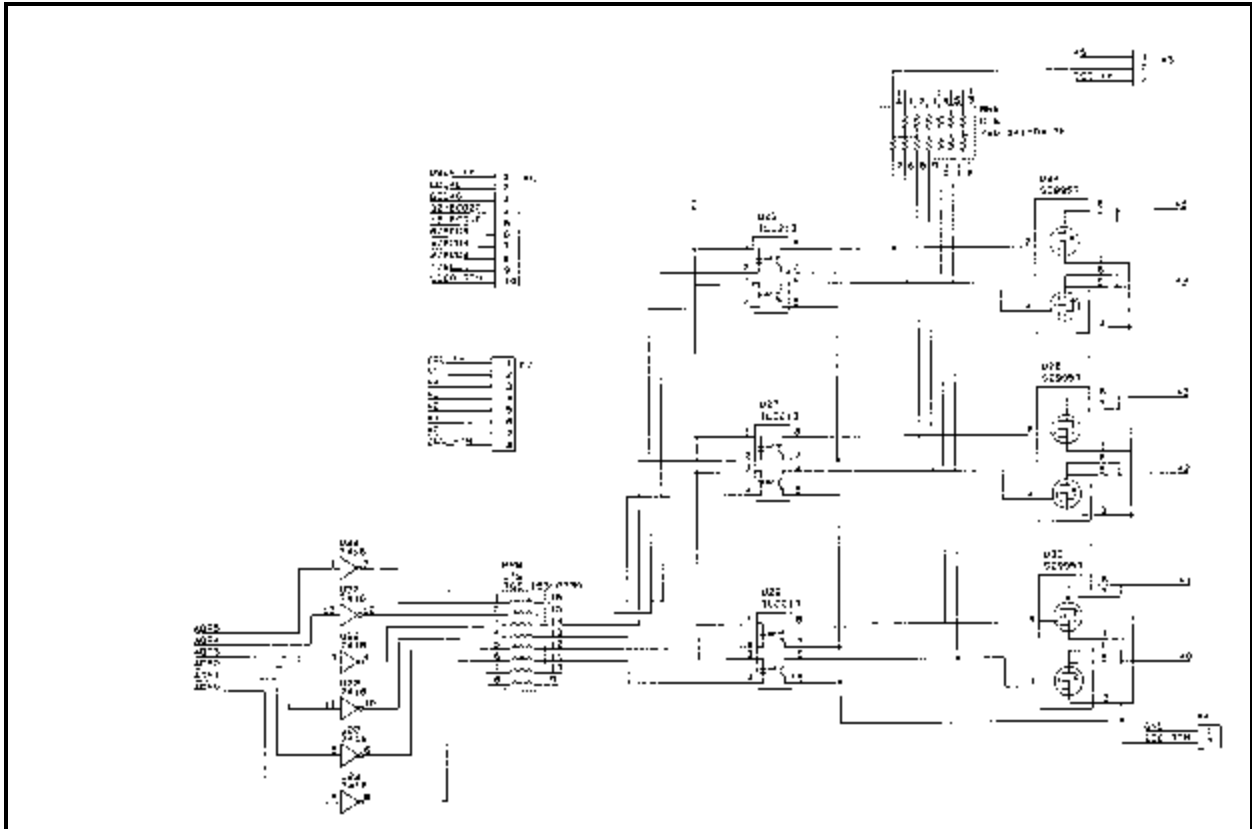

Figure 12 - MACU2 Logic Board - Part 4

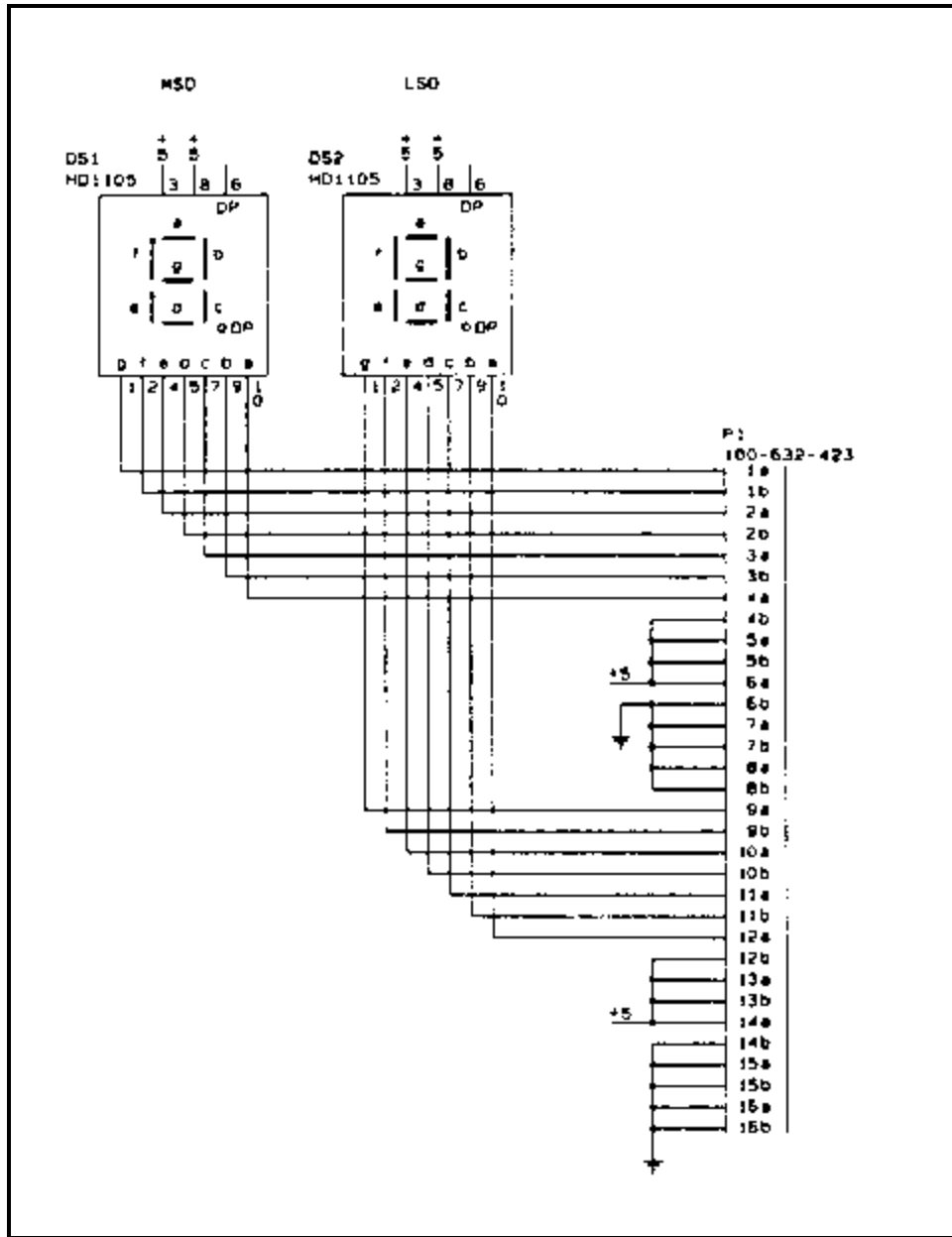

Figure 13 - MACU2 Address Display Board

EXPLODED VIEW OF THE MACU2

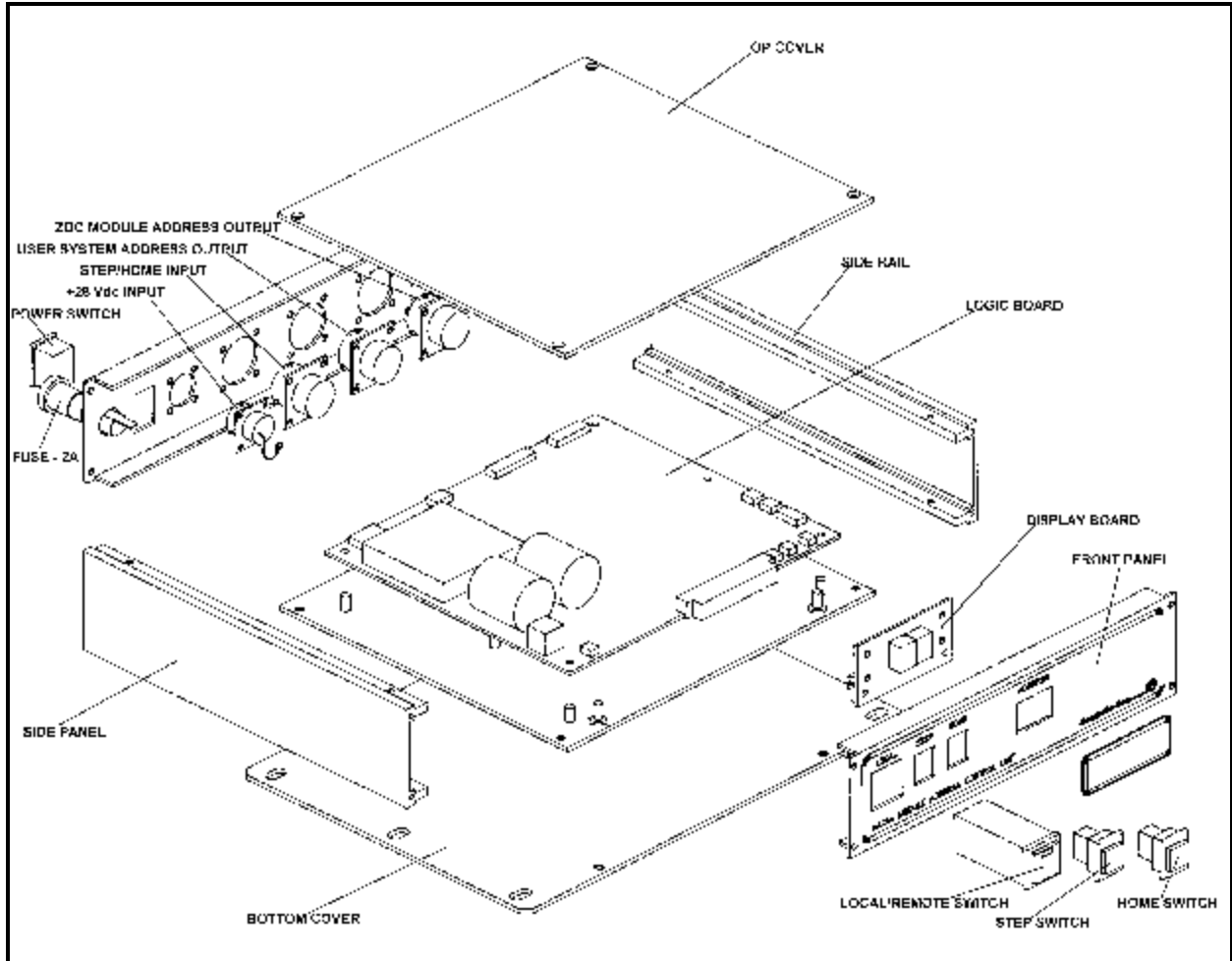

Figure 14 - MACU2 - Exploded View